



# Digital Cylinder AX (Z5) Modularity

---

Manual

14.03.2024

**Simons Voss**  
technologies

## Contents

1.	General safety instructions .....	3
2.	Product-specific safety instructions .....	5
3.	Accessories and tools .....	6
3.1	Length modularity.....	6
3.2	Cam.....	7
3.3	Tools.....	8
4.	Extend Cylinder AX.....	9
5.	Shorten Cylinder AX.....	21
6.	Combine CO cylinders to FD .....	33
7.	Reduce CO cylinders to HZ.....	48
8.	Replacing the cam.....	61
9.	Help and other information .....	74

## 1. General safety instructions

**Signal word: Possible immediate effects of non-compliance**

WARNING: Death or serious injury (possible, but unlikely)

IMPORTANT: Property damage or malfunction

NOTE: Low or none



### WARNING

#### Blocked access

Access through a door may stay blocked due to incorrectly fitted and/or incorrectly programmed components. SimonsVoss Technologies GmbH is not liable for the consequences of blocked access such as access to injured or endangered persons, material damage or other damage!

#### Blocked access through manipulation of the product

If you change the product on your own, malfunctions can occur and access through a door can be blocked.

- ❑ Modify the product only when needed and only in the manner described in the documentation.

### IMPORTANT

#### Damage resulting from liquids

This product contains electronic and/or mechanic components that may be damaged by liquids of any kind.

- ❑ Keep liquids away from the electronics.

#### Damage resulting from aggressive cleaning agents

The surface of this product may be damaged as a result of the use of unsuitable cleaning agents.

- ❑ Only use cleaning agents that are suitable for plastic or metal surfaces.



### NOTE

#### Intended use

SmartIntego-products are designed exclusively for opening and closing doors and similar objects.

- ❑ Do not use SmartIntego products for any other purposes.

#### Qualifications required

The installation and commissioning requires specialized knowledge.

- ❑ Only trained personnel may install and commission the product.

## Incorrect installation

SimonsVoss Technologies GmbH accepts no liability for damage caused to doors or components due to incorrect fitting or installation.

Modifications or further technical developments cannot be excluded and may be implemented without notice.

The German language version is the original instruction manual. Other languages (drafting in the contract language) are translations of the original instructions.

Read and follow all installation, installation, and commissioning instructions. Pass these instructions and any maintenance instructions to the user.

---

## 2. Product-specific safety instructions

---



### WARNING

#### Malfunction of the anti-panic function due to unauthorised manipulation



In its anti-panic version, the SI Digital Cylinder AX has a permanently installed anti-panic module and is modular in length to a limited extent: outer side as required, inner side from 50 mm and half cylinder from 50 mm.

1. Do not attempt to dismantle the anti-panic module as this may damage it.
  2. Perform a battery test every time that you modify it.
-

### 3. Accessories and tools

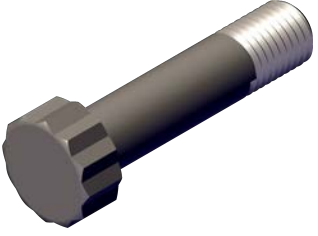

#### 3.1 Length modularity



The profile cylinder can be extended and shortened with the following parts:

Extension bolt	Core extension for the profile	Profile extension
 <ul style="list-style-type: none"> <li>■ Z5.BOLT.XX (XX = required basic length)</li> </ul>	 <ul style="list-style-type: none"> <li>■ Z5.CORE.05: 5 mm</li> <li>■ Z5.CORE.10: 10 mm</li> <li>■ Z5.CORE.20: 20 mm</li> </ul>	 <ul style="list-style-type: none"> <li>■ Z5.PROFILE.05: 5 mm</li> <li>■ Z5.PROFILE.10: 10 mm</li> <li>■ Z5.PROFILE.20: 20 mm</li> </ul>

#### Clamps

 <ul style="list-style-type: none"> <li>■ Z5.CLAMPS</li> </ul> <p>Set contains 50 units.</p>
---





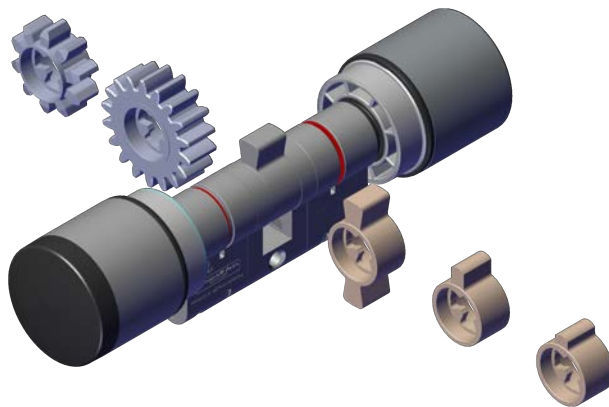

Cylinder centre piece	Half cylinder centre piece	Half cylinder centre section with multi-point
 <ul style="list-style-type: none"> <li>■ Z5.CNT.EU</li> </ul>	 <ul style="list-style-type: none"> <li>■ Z5.CNT.HZ</li> </ul>	 <ul style="list-style-type: none"> <li>■ Z5.CNT.HZ.MR</li> </ul>

Inner thumb-turn mount	Inside blank profile without thumb-turn	Thumb-turn mount for glass door thumb-turn
 <p>■ Z5.PR.IN</p>	 <p>For .OK variant ■ Z5.PR.OK</p>	 <p>Profile length 30 mm (extensible) ■ Z5.PR.GD</p>

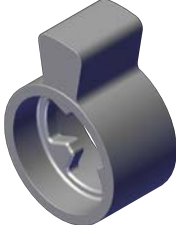
### 3.2 Cam

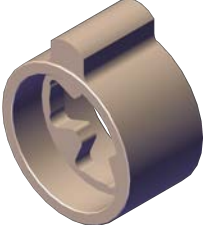
You can also choose between different cams:



Standard cam	Cam PM1 (long)	Cam PM2 (short)
 <p>■ Z5.CAM.WP</p>	 <p>■ Z5.CAM.PM1</p>	 <p>■ Z5.CAM.PM2</p>
Double cam	Cam gear, 10 teeth	Cam gear, 18 teeth
 <p>■ Z5.CAM.DOUBLE</p>	 <p>■ Z5.CAM.GEAR10</p>	 <p>■ Z5.GEAR.18</p>

Dimensional drawings can be found in Section Cam dimensions; see *Replacing the cam* [▶ 61] for installation.

### 3.3 Tools

Various tools are available to adjust the SI Digital Cylinder AX:

Lifter (Z5.LIFTER)	Spacer (Z5.SPACER)	Terminal block (Z5.BLOCK)
		

The SI Digital Cylinder AX thumb turn installation tool is designed so that you can use it to hold the SI Digital Cylinder AX in place. Position it with the flat side on a flat surface and place the SI Digital Cylinder AX together with the thumb-turn in the installation tool. Reassembly is easier when the SI Digital Cylinder AX is in the holder.

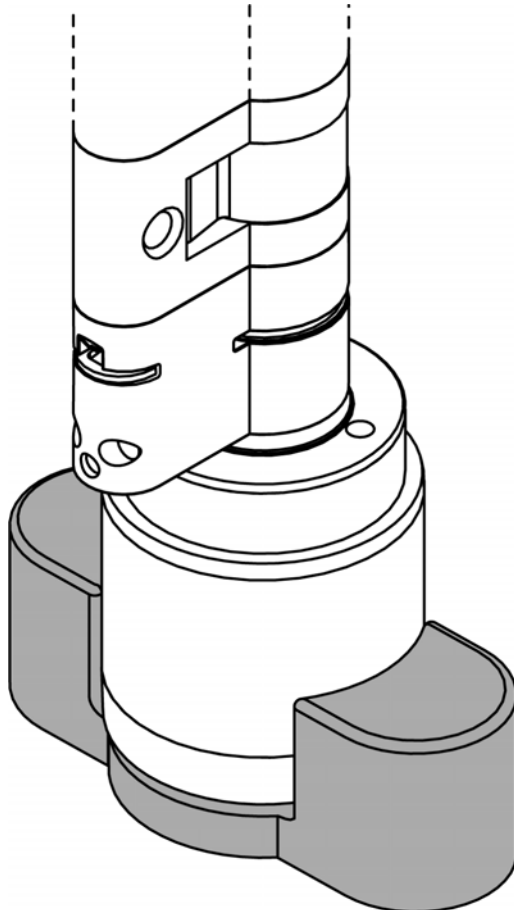



#### 4. Extend Cylinder AX

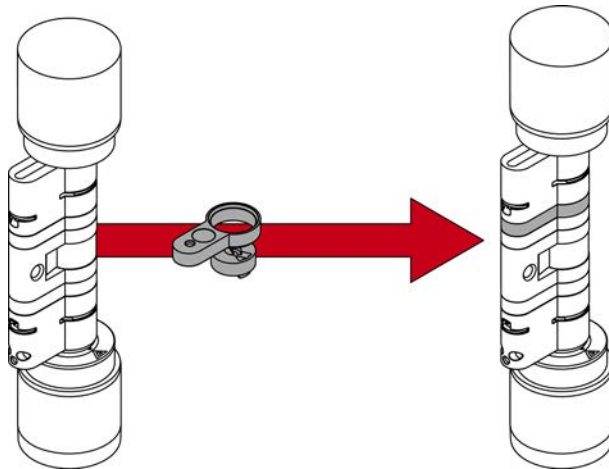

The core extension and profile extension must be the same length. You also need an extension bolt for the desired length.

- ✓ Extractor for releasing the clamp
- ✓ Spacer for aligning the extension bolt
- ✓ Clamp block for pressing in the clamp

1. Place the Cylinder AX in the thumb-turn assembly tool.

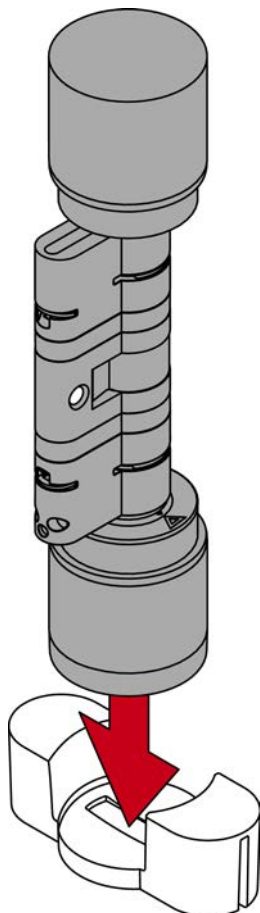

2. Hook the tip of the extractor into the clamp.

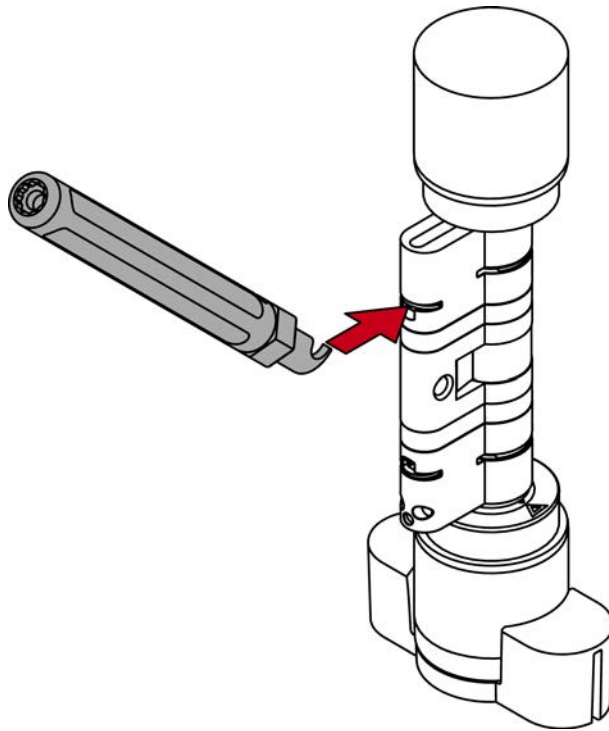

3. Lever the clamp out of the profile cylinder by moving the extractor to the centre of the cylinder.

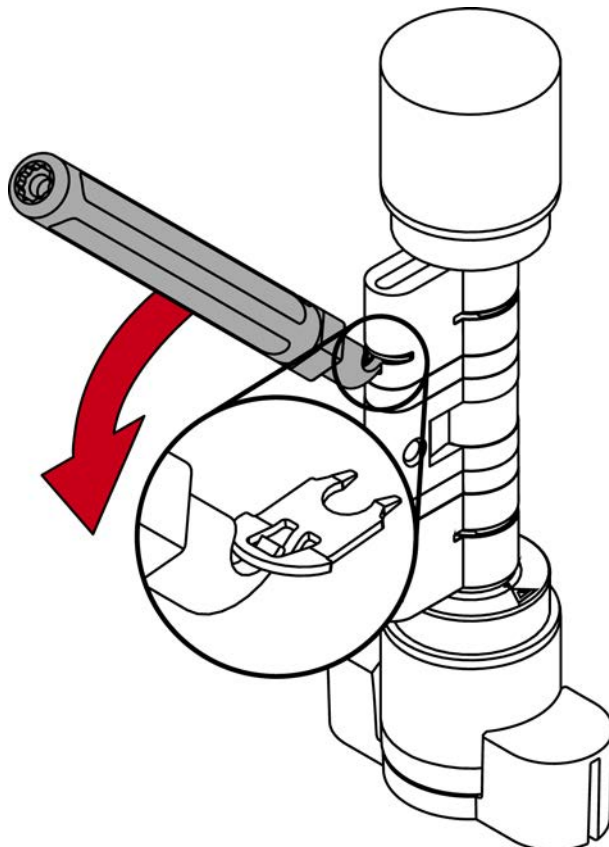

4. Pull the clamp completely out of the profile cylinder.

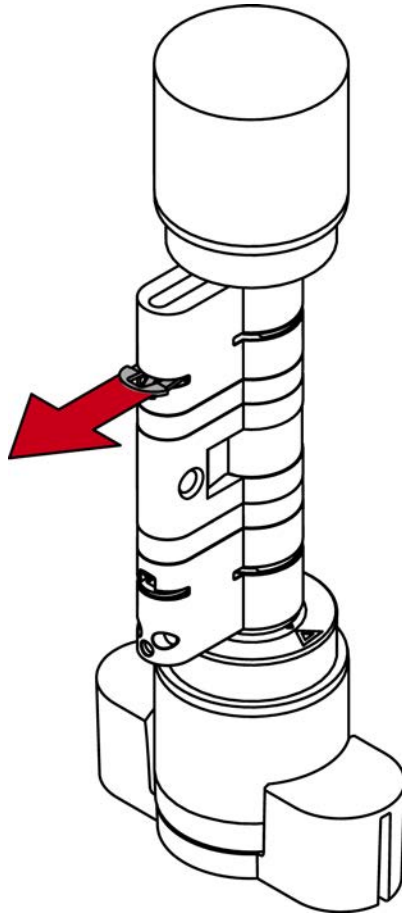

5. Disassemble the two cylinder halves.

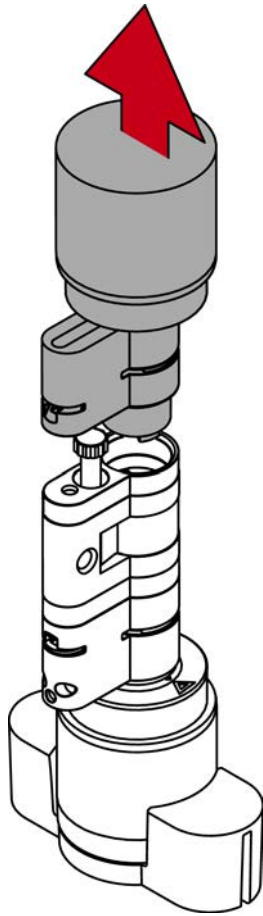

6. Use the extractor to unscrew the extension bolt.

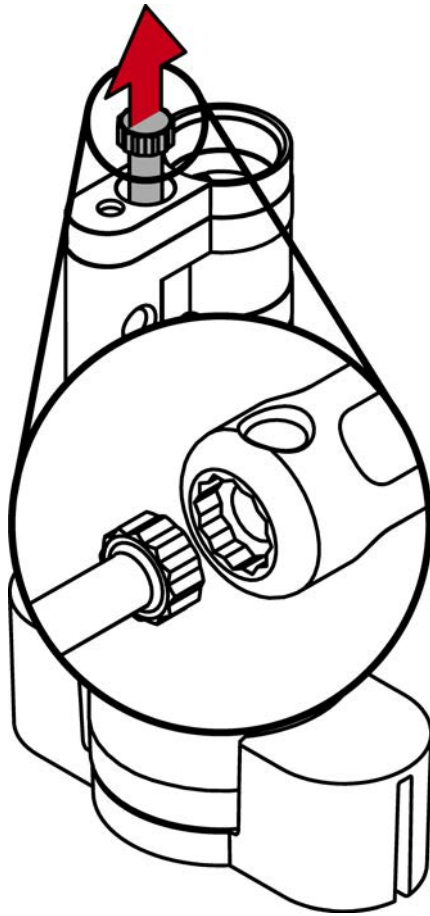

7. Insert suitable core extensions.

8. Attach suitable profile extensions.

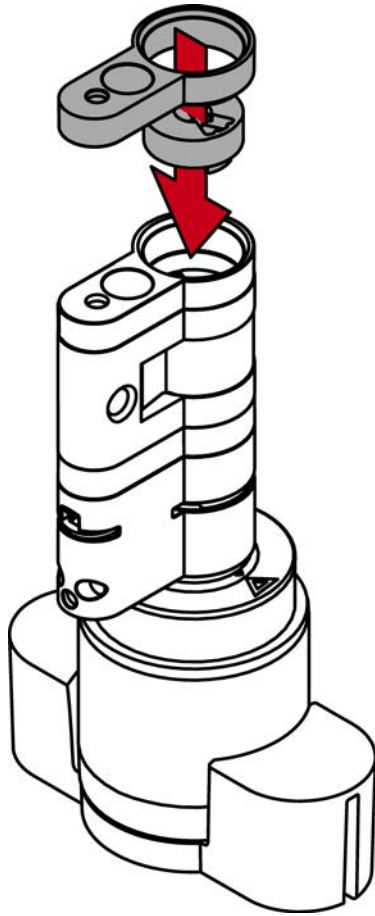

9. Place the spacer.

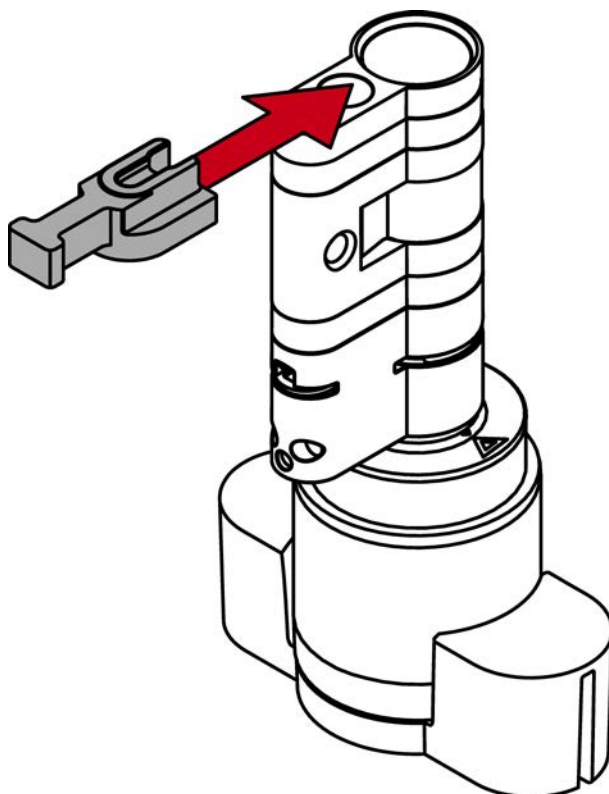

10. Screw in a suitable extension bolt with the extractor until it rests on the spacer.



**NOTE**

**Length on bolt head**

You will find a number on the bolt head. This number is the length of the cylinder profile to which the bolt fits.

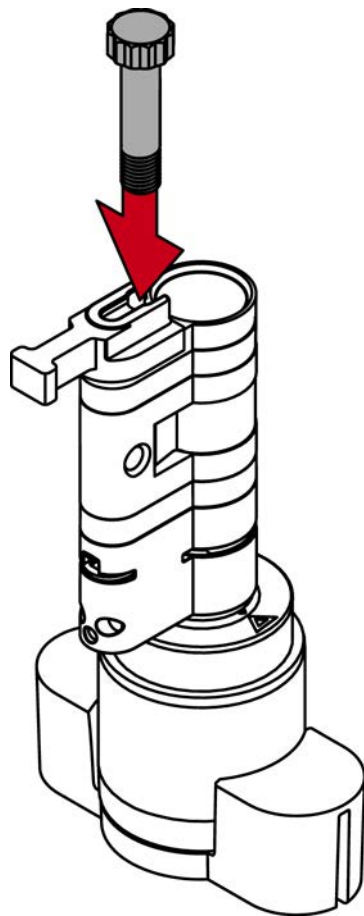

11. Reassemble the two cylinder halves.

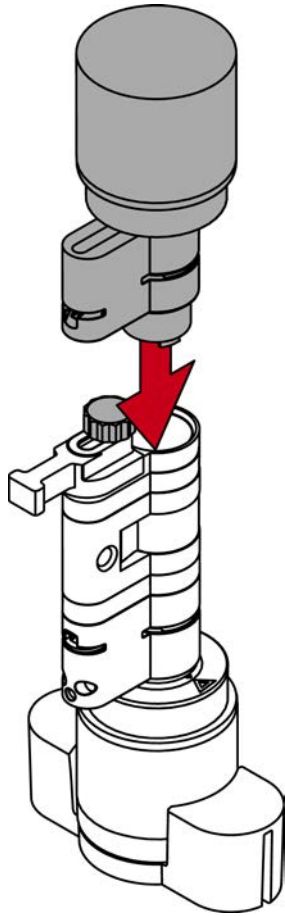

↳ Extension bolt is protected against twisting.



12. Pull the spacer off again.

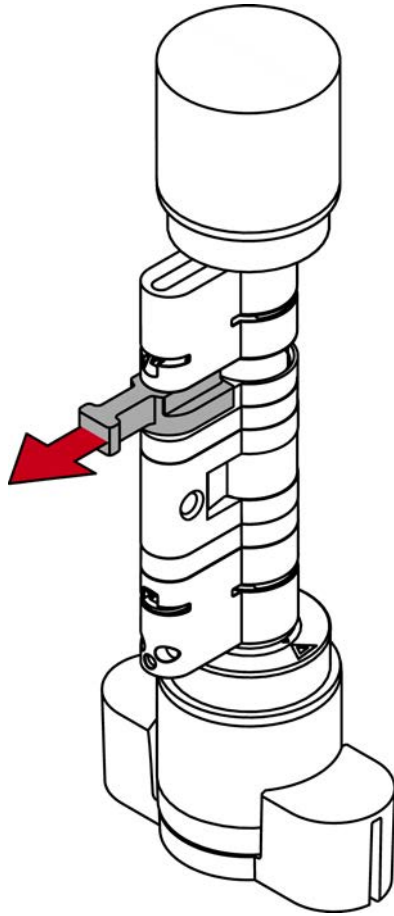

13. Push the halves together completely.

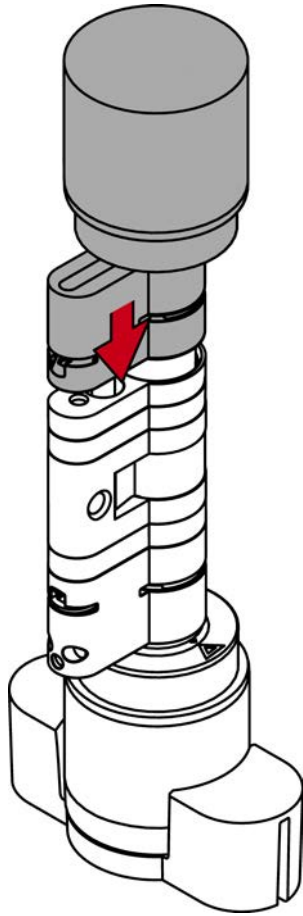

14. Place the clip back into the slot of the profile cylinder with its lug facing the fastening screw and press the clamp with your thumb so that it can no longer fall out.

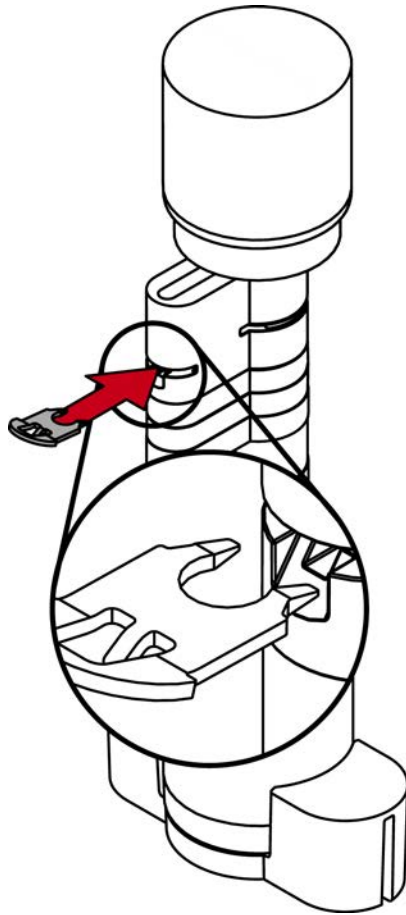

15. Insert the cylinder into the clamping block so that the profile cylinder and the thumb-turn lie flush in the recesses.

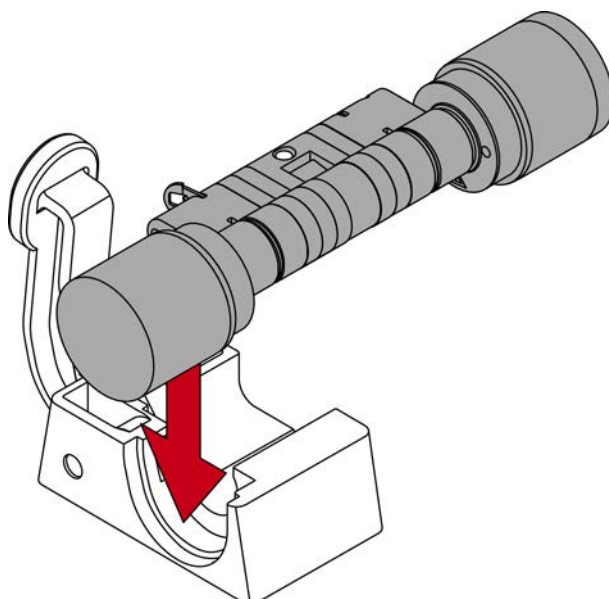

- ↳ The lever of the clamping block is reinforced at one point with a metal plate. The bracket that was previously inserted lies opposite this metal plate.

16. Push the clamp block lever towards the base plate until the clamp is fully seated in the profile cylinder.

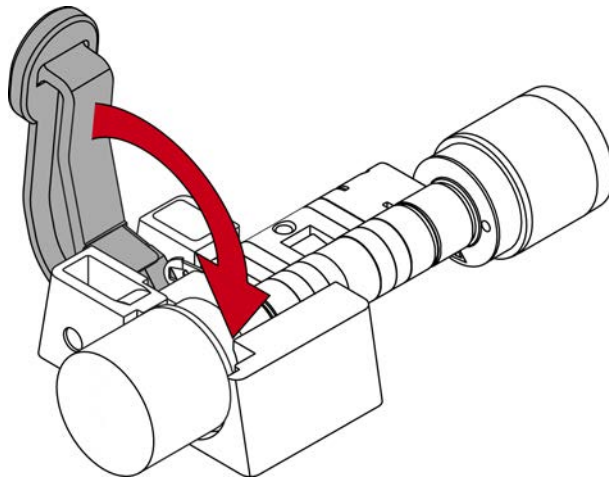

- ↳ Cylinder AX is extended.

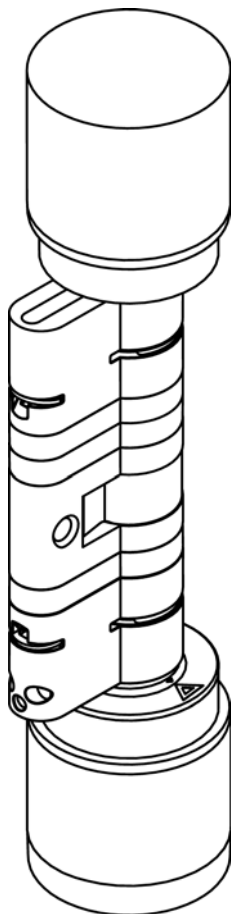

## 5. Shorten Cylinder AX

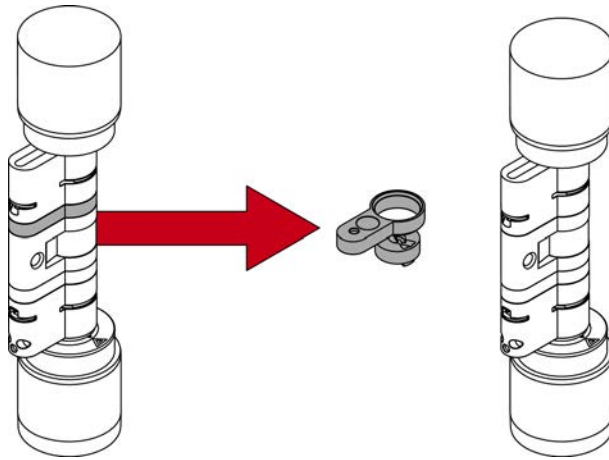

You need a bolt for the desired length.

- ✓ Extractor for releasing the clamp
- ✓ Spacer for aligning the bolt
- ✓ Clamp block for pressing in the clamp

1. Place the Cylinder AX in the thumb-turn assembly tool.

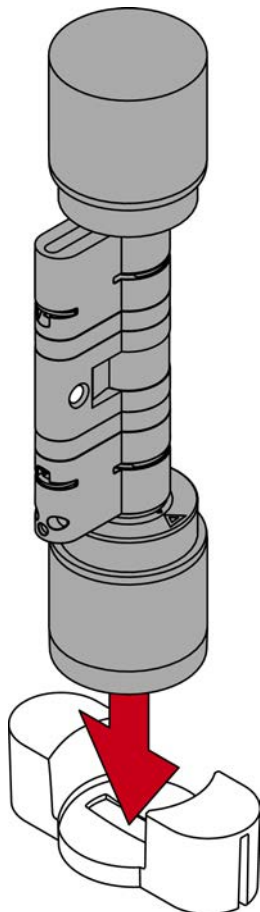

2. Hook the tip of the extractor into the clamp.

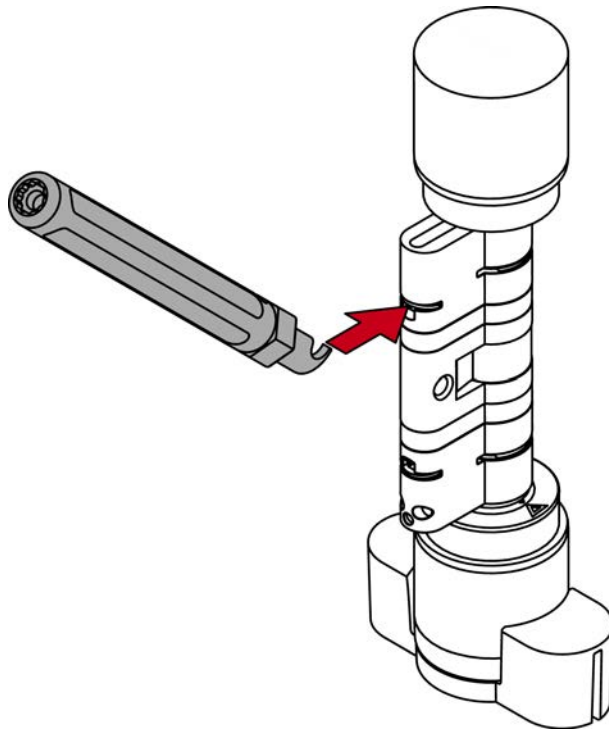

3. Lever the clamp out of the profile cylinder by moving the extractor to the centre of the cylinder.

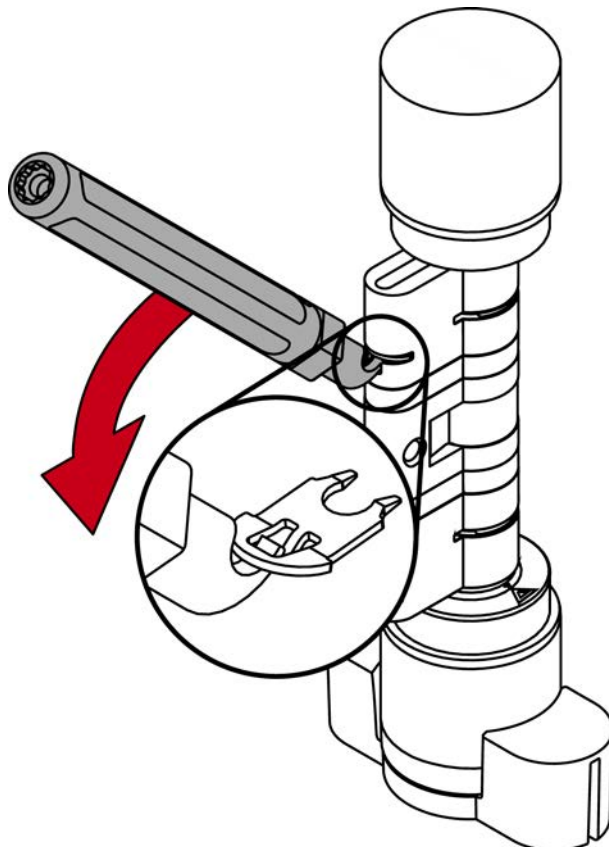

4. Pull the clamp completely out of the profile cylinder.

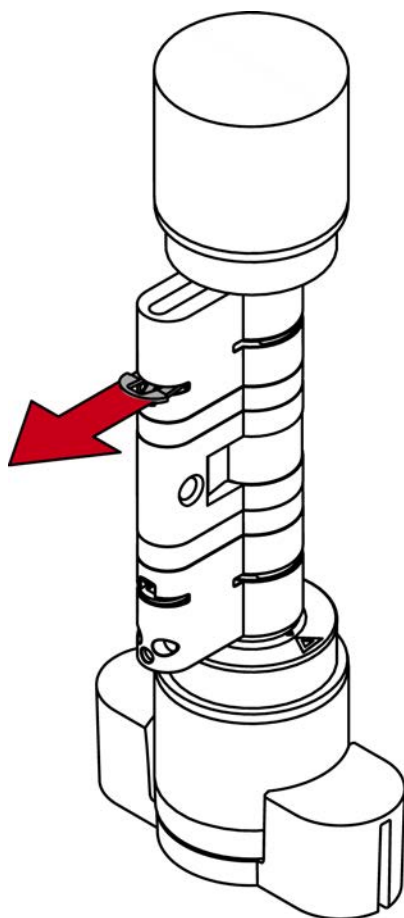

5. Disassemble the two cylinder halves.

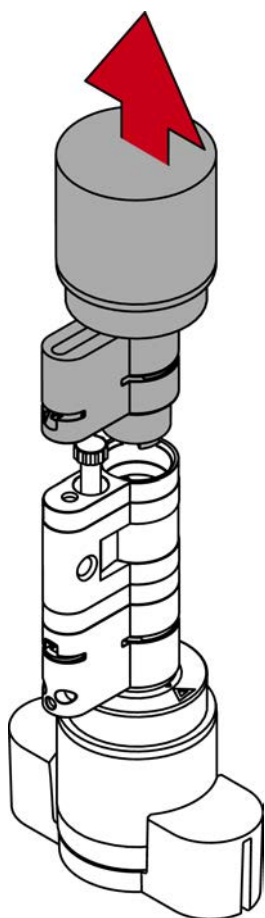



6. Unscrew the bolt with the extractor.

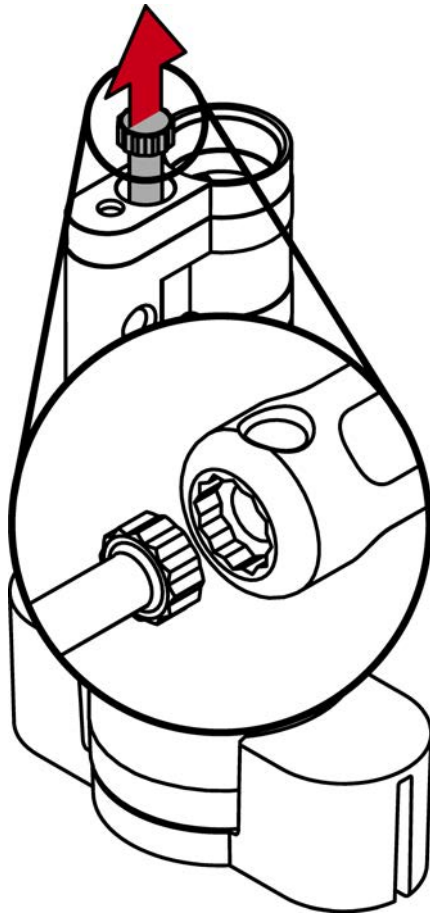

7. Remove the profile extension.

8. Remove the core extension.

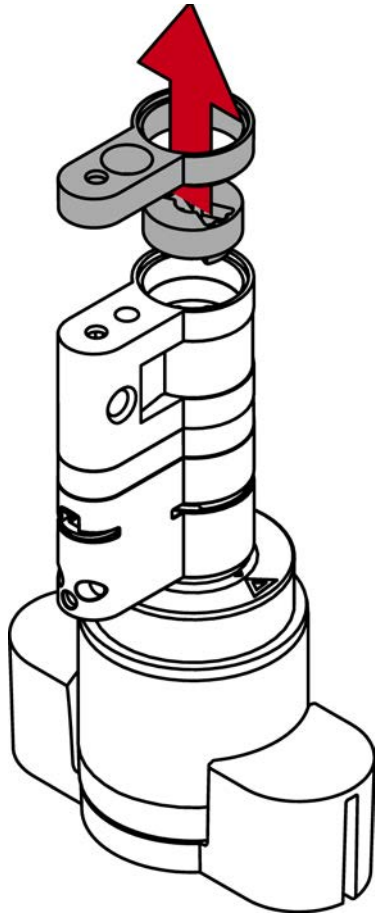

9. Place the spacer.

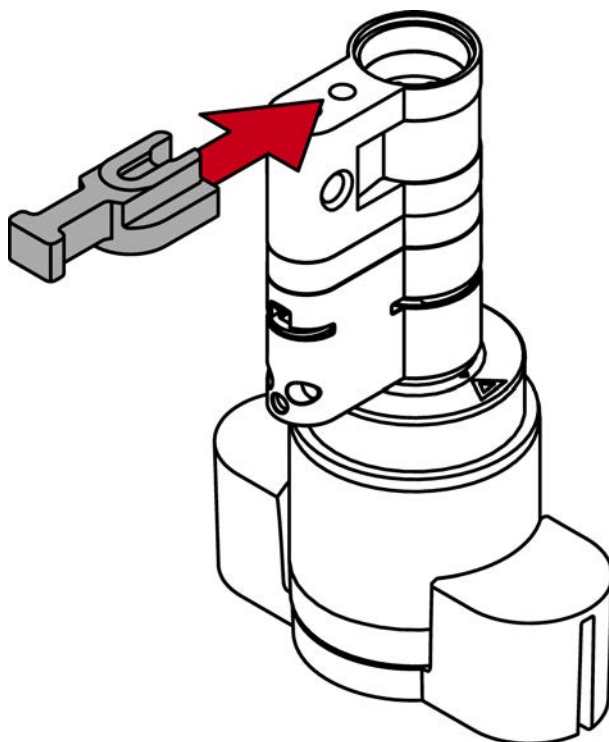

10. Screw in a suitable bolt with the extractor until it rests on the spacer.



**NOTE**

**Length on bolt head**

You will find a number on the bolt head. This number is the length of the cylinder profile to which the bolt fits.

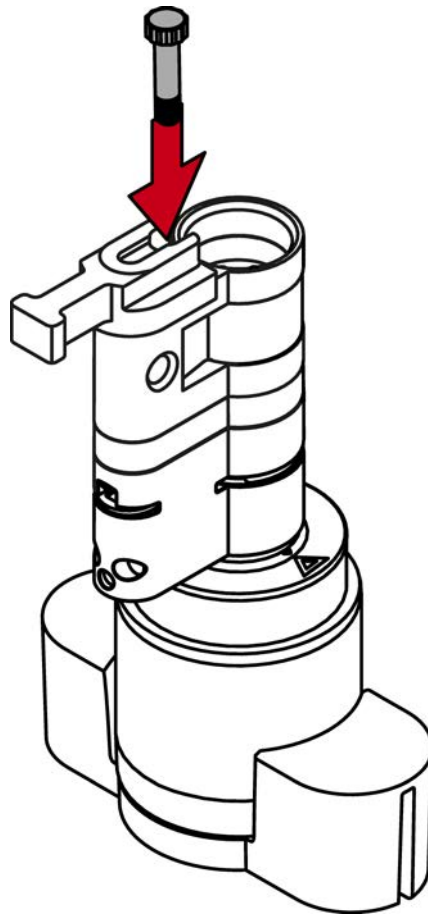

11. Reassemble the two cylinder halves.

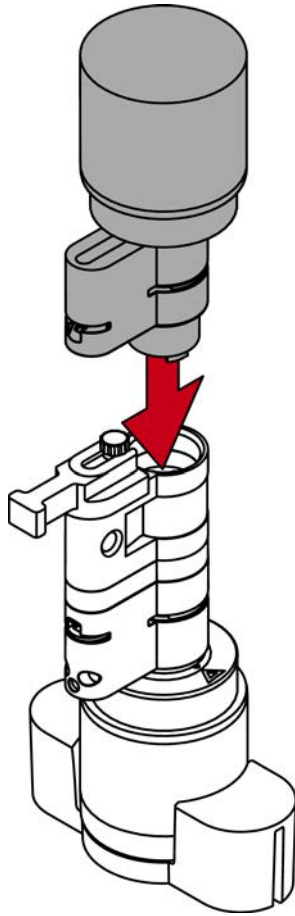

↳ Bolt is protected against twisting.

12. Pull the spacer off again.

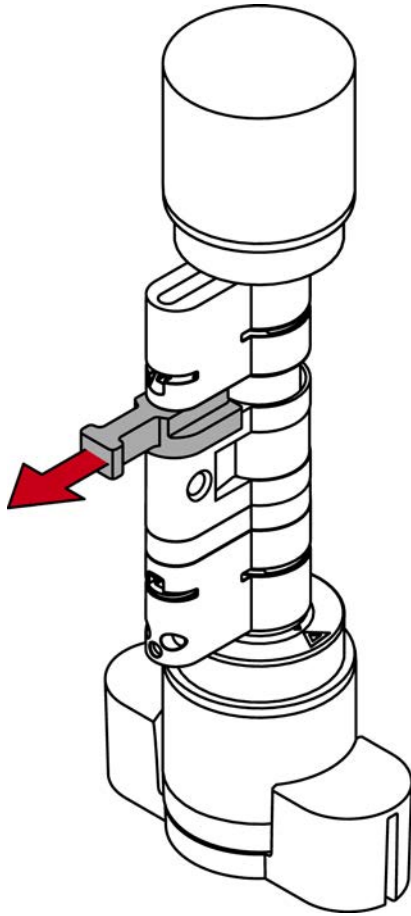

13. Push the halves together completely.

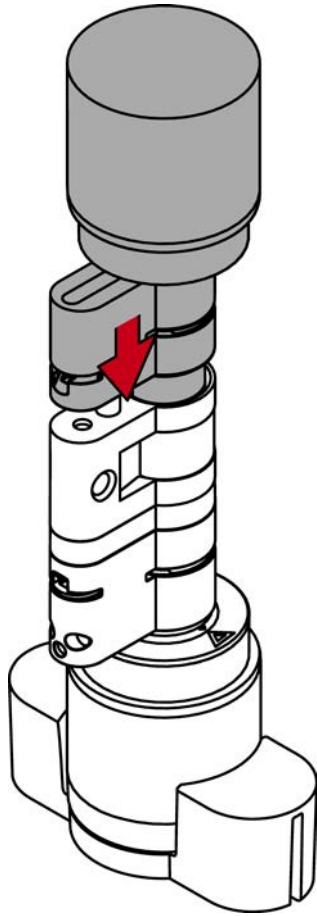

14. Refit the clip into the slot of the profile cylinder with the lug facing the fastening screw.

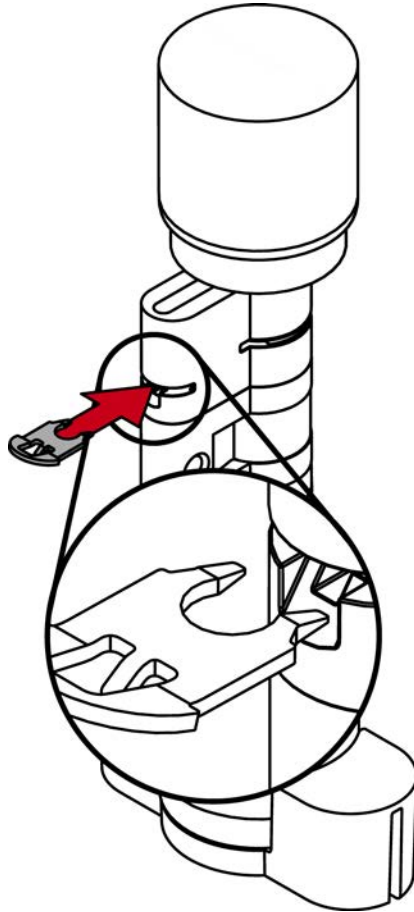

15. Insert the cylinder into the clamping block so that the profile cylinder and the thumb-turn lie flush in the recesses.

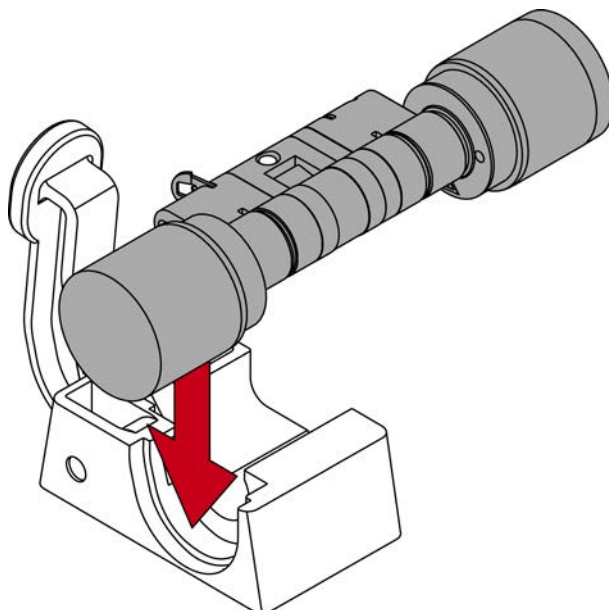

- ↳ The lever of the clamping block is reinforced at one point with a metal plate. The bracket that was previously inserted lies opposite this metal plate.

16. Push the clamp block lever towards the base plate until the clamp is fully seated in the profile cylinder.

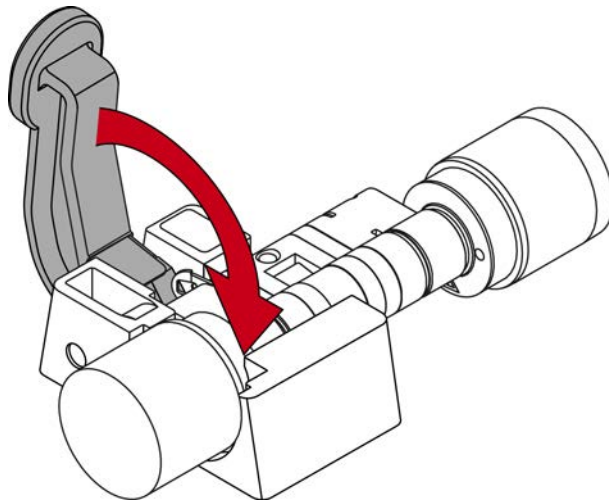

- ↳ Cylinder AX is shortened.

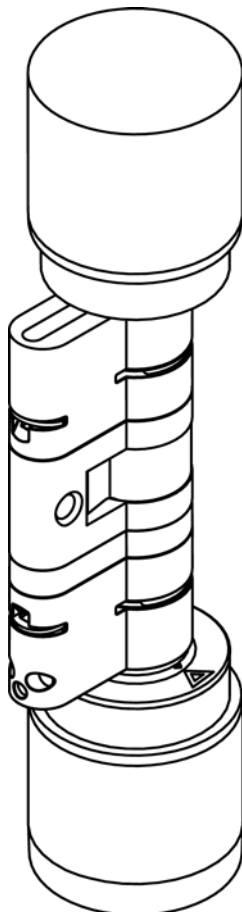



## 6. Combine CO cylinders to FD

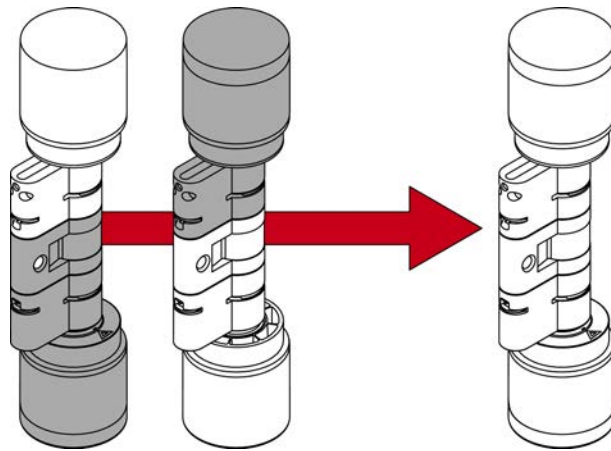

You can assemble a freely rotating AX cylinder from two AX comfort cylinders.

- ✓ Extractor for releasing the clamp
- ✓ Spacer for aligning the extension bolt
- ✓ Clamp block for pressing in the clamp

1. Place the first comfort cylinder AX in the thumb-turn assembly tool with the mechanical thumb-turn facing upwards.

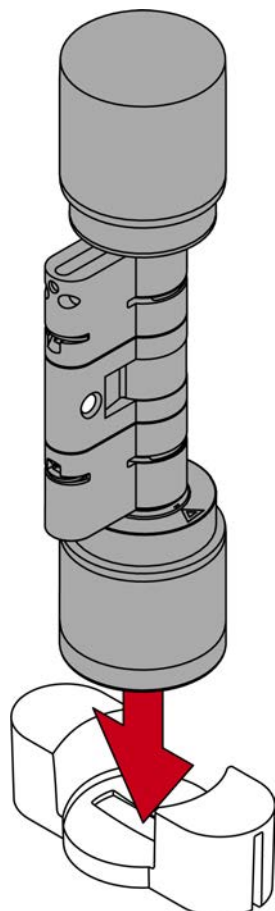

2. Hook the tip of the extractor into the clamp.

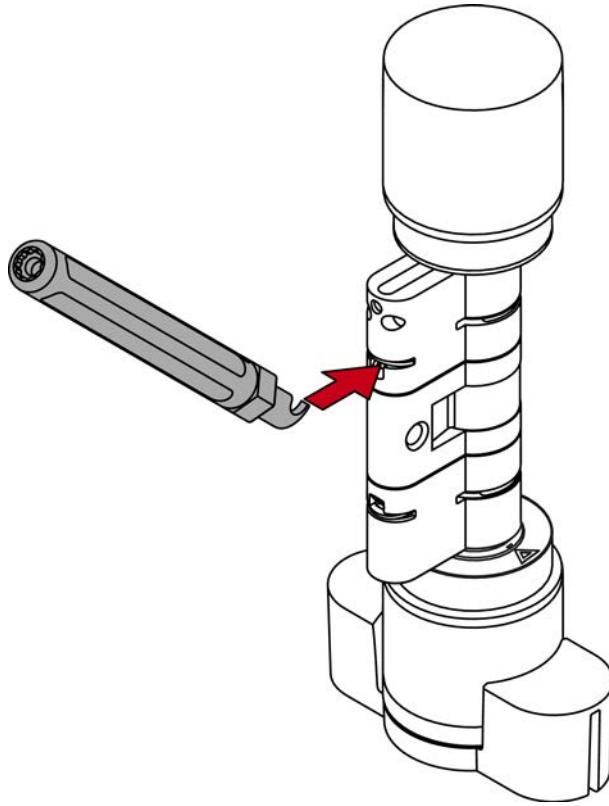

3. Lever the clamp out of the profile cylinder by moving the extractor to the centre of the cylinder.

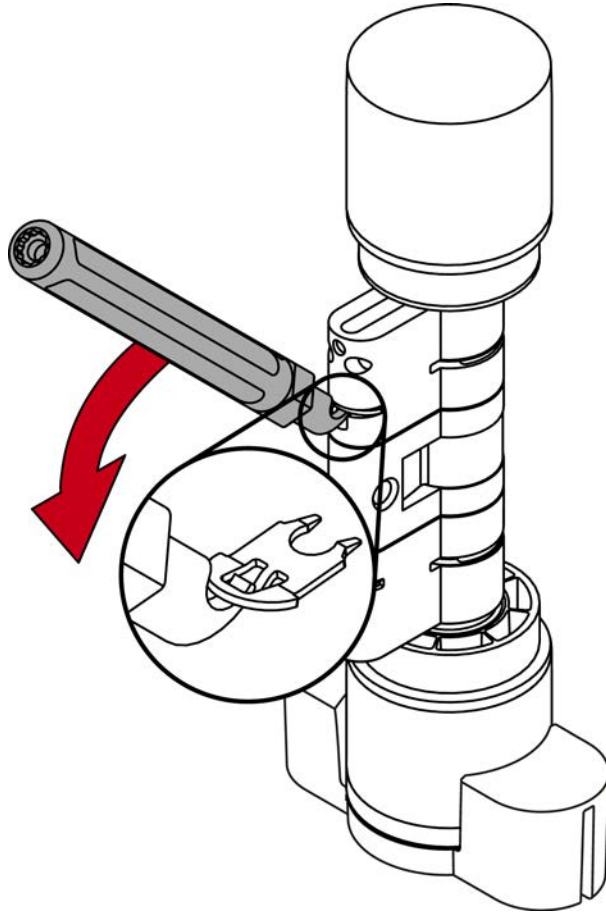

4. Pull the clamp completely out of the profile cylinder.

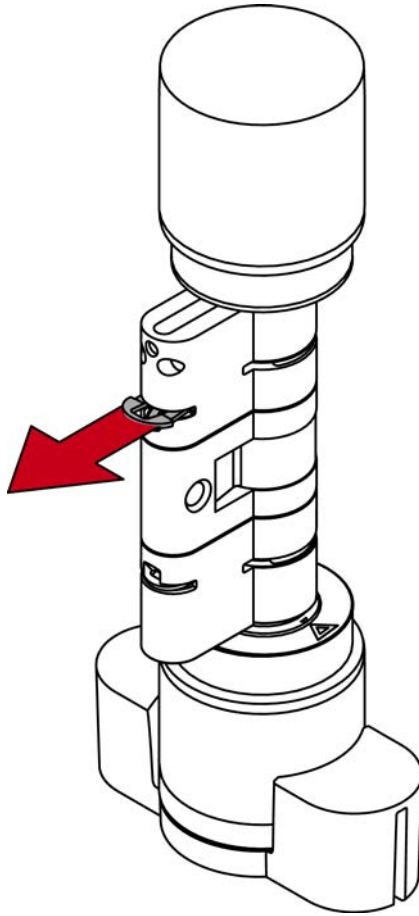

5. Disassemble the two cylinder halves.

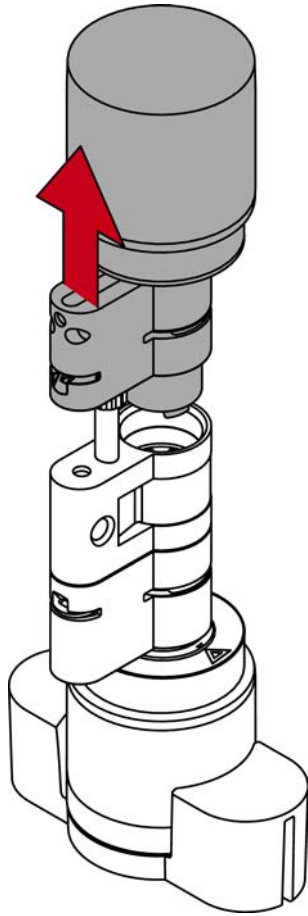

↳ First cylinder half prepared with centre piece and tappet piece.

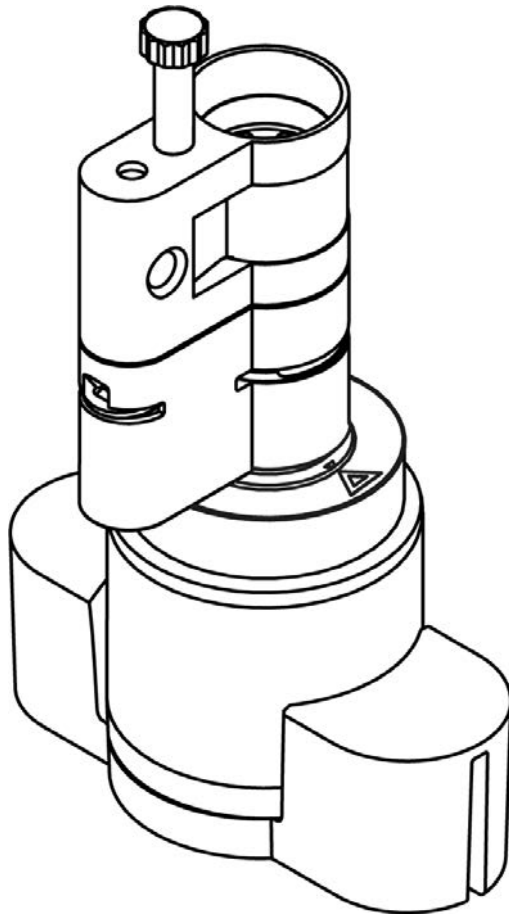

6. Place the second comfort cylinder AX in the thumb-turn assembly tool with the electronic thumb-turn facing upwards.

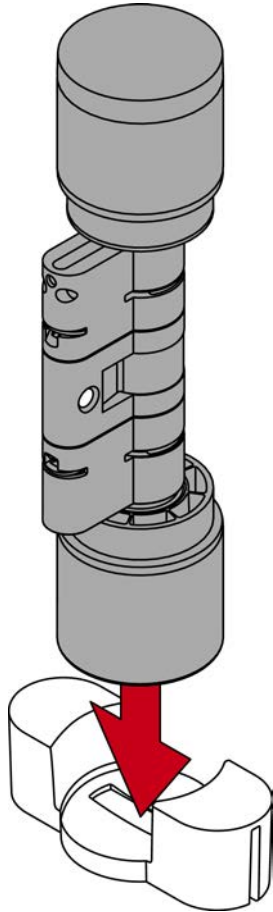

7. Hook the tip of the extractor into the clamp.

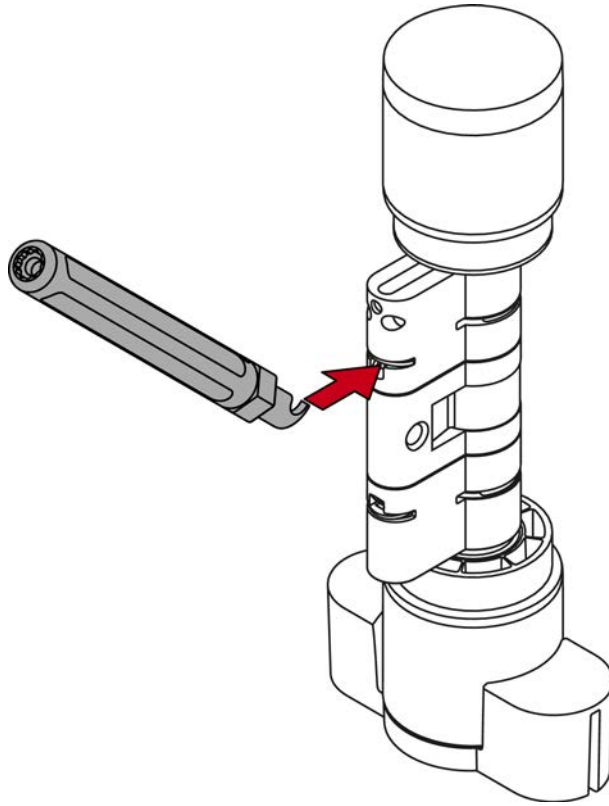



8. Lever the clamp out of the profile cylinder by moving the extractor to the centre of the cylinder.

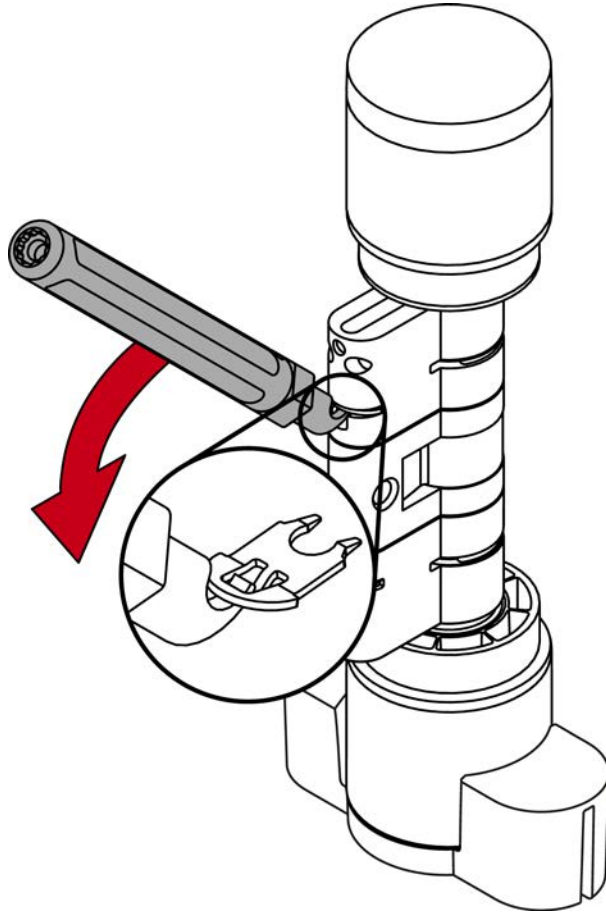

9. Pull the clamp completely out of the profile cylinder.

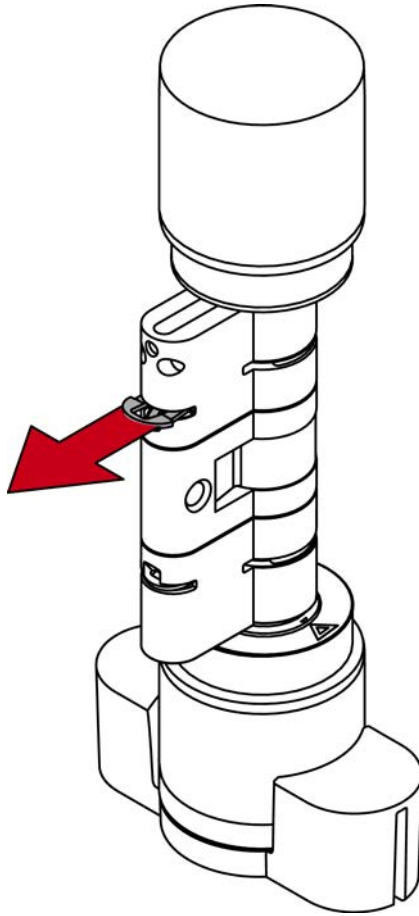

10. Disassemble the two cylinder halves.

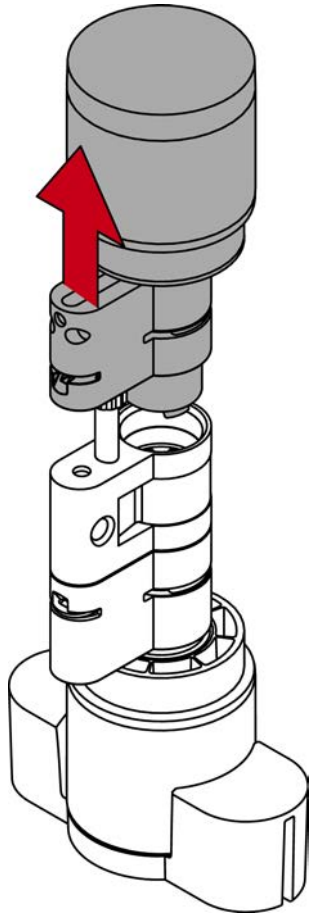

↳ Second cylinder half prepared without centre piece.

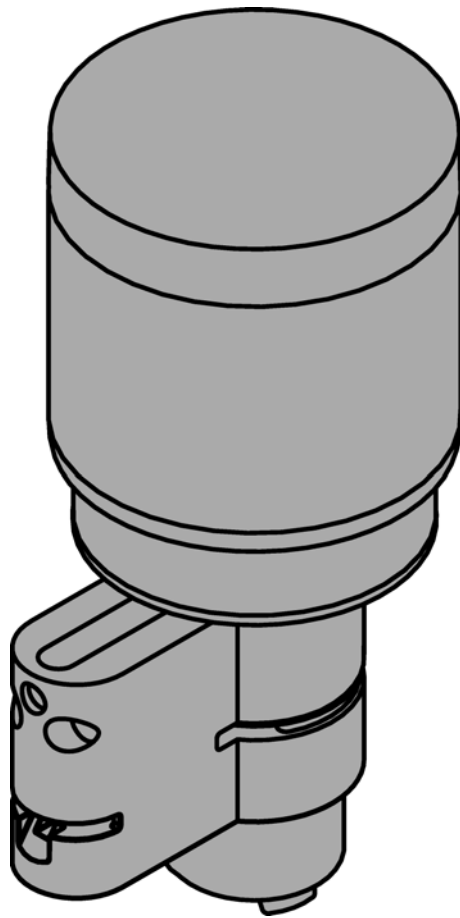

11. Place the first cylinder half on the second cylinder half.

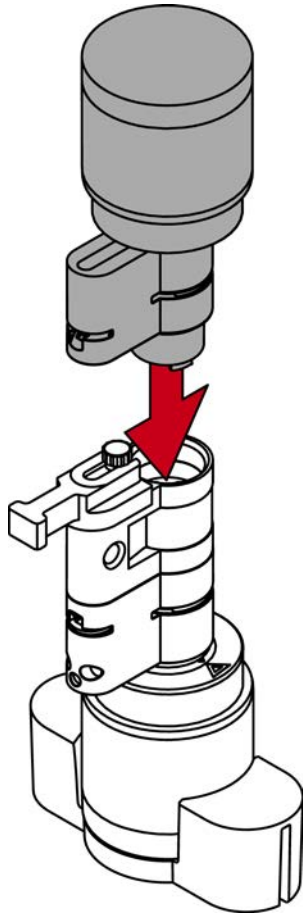

12. Refit the clip into the slot of the profile cylinder with the lug facing the fastening screw.

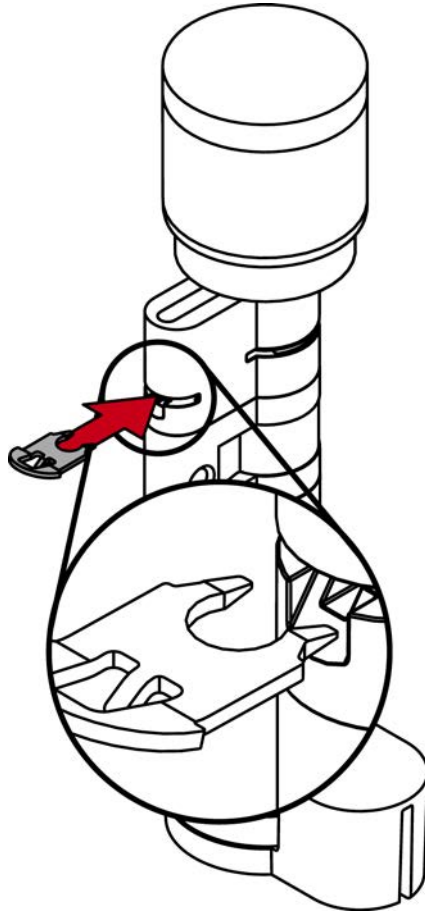

13. Insert the cylinder into the clamping block so that the profile cylinder and the thumb-turn lie flush in the recesses.

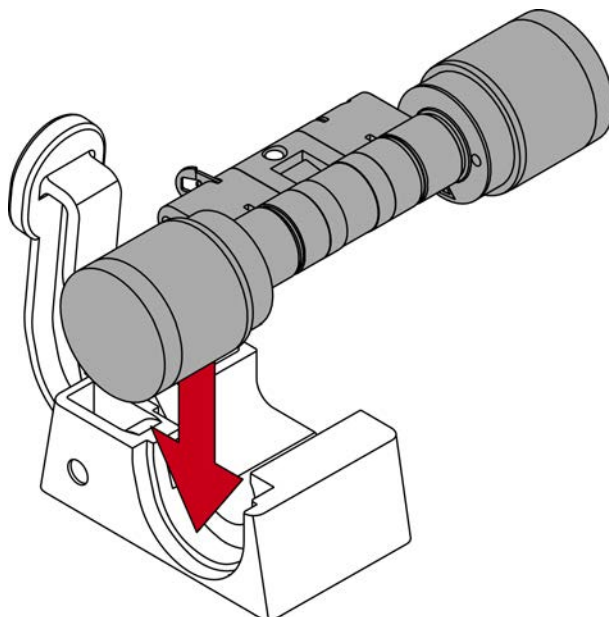

- ↳ The lever of the clamping block is reinforced at one point with a metal plate. The bracket that was previously inserted lies opposite this metal plate.

14. Push the clamp block lever towards the base plate until the clamp is fully seated in the profile cylinder.

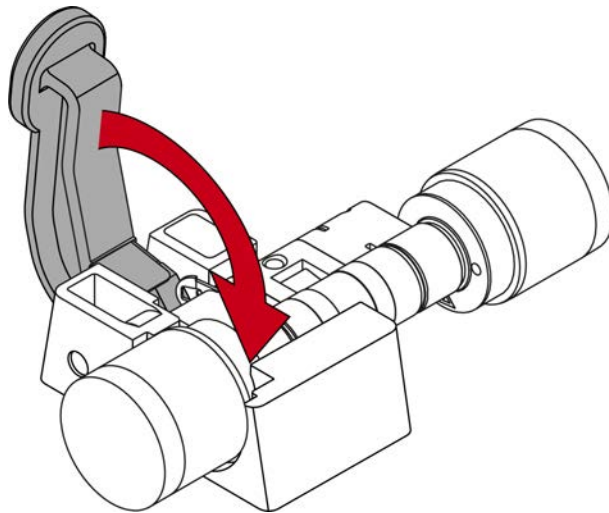

- ↳ Freely rotating cylinder fully assembled.

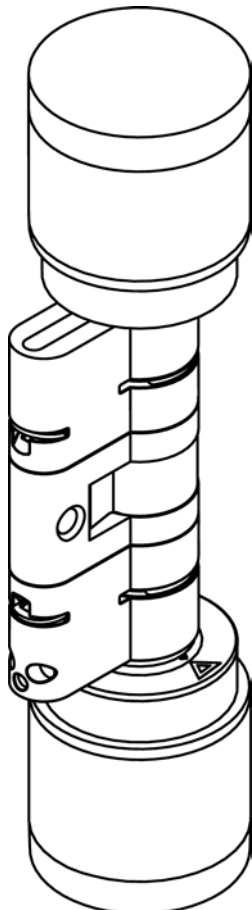

## 7. Reduce CO cylinders to HZ

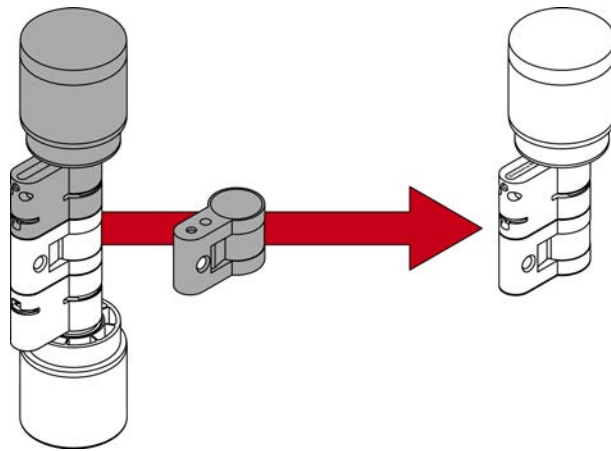

You can use a special centre piece to assemble a half cylinder from an AX comfort cylinder or a freely rotating cylinder.

- ✓ Extractor for releasing the clamp
- ✓ Spacer for aligning the extension bolt
- ✓ Clamp block for pressing in the clamp
- ✓ Half Cylinder Center Section

1. Place the Cylinder AX in the thumb-turn assembly tool with the electronic thumb-turn facing upwards.

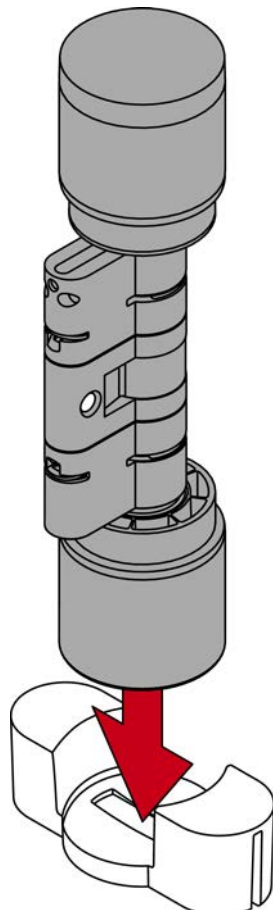



2. Hook the tip of the extractor into the clamp.

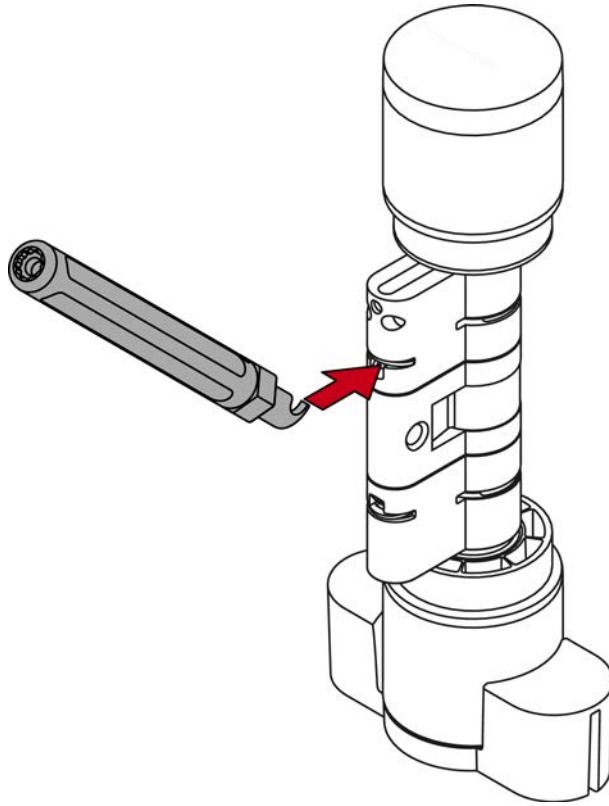

3. Lever the clamp out of the profile cylinder by moving the extractor to the centre of the cylinder.

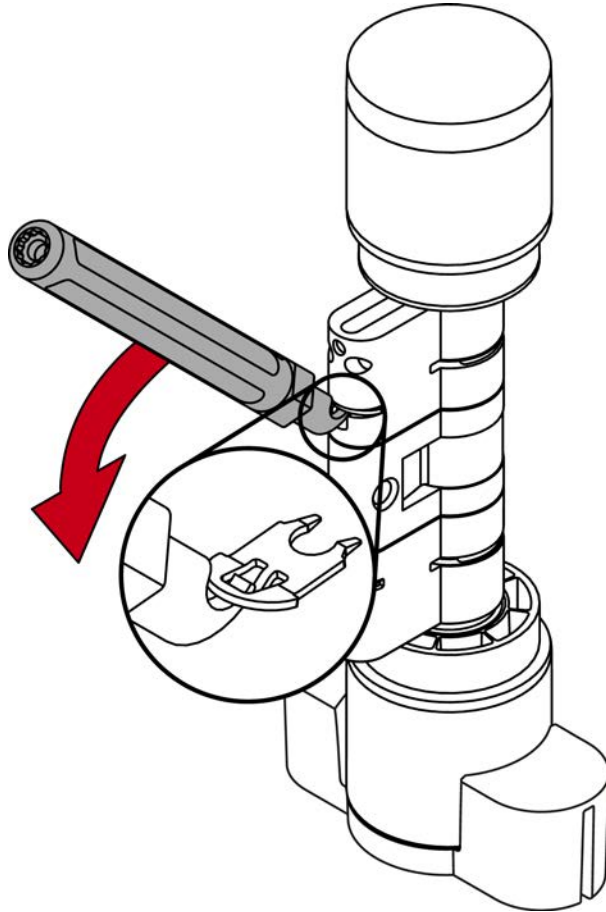

4. Pull the clamp completely out of the profile cylinder.

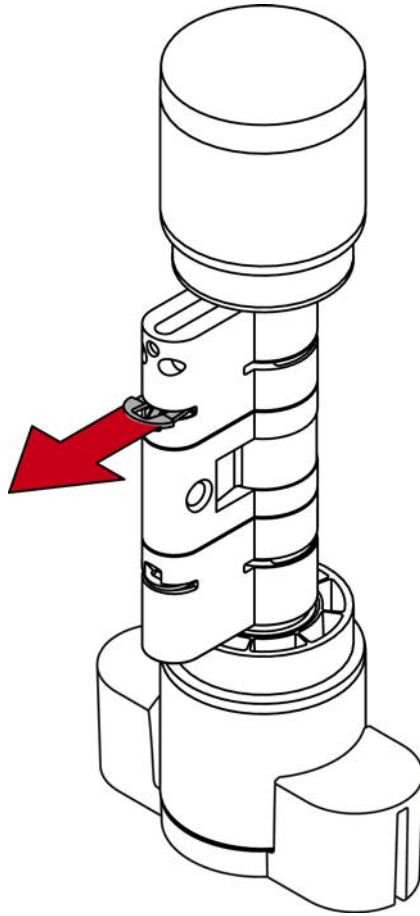

5. Disassemble the two cylinder halves.

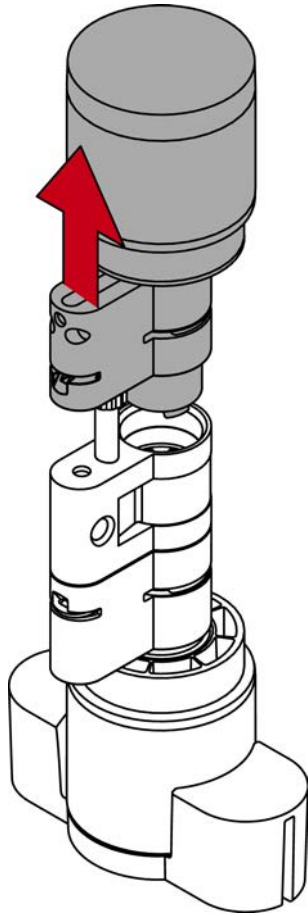

↳ First cylinder half prepared without centre piece.

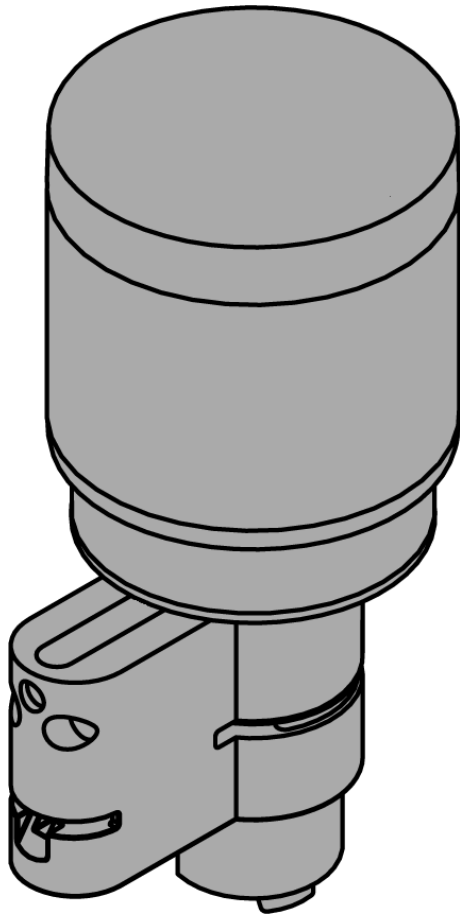

6. Place the spacer on the half-cylinder centre piece.

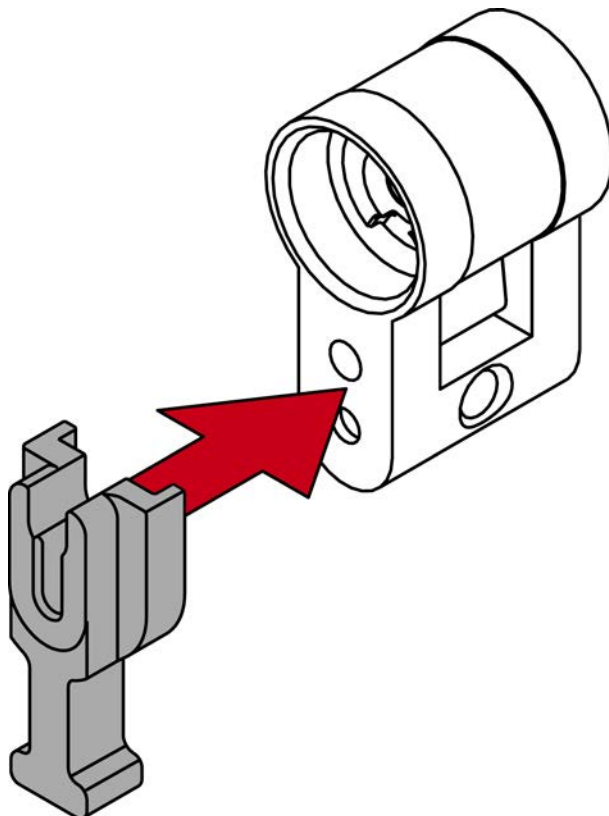

7. Screw in a suitable extension bolt with the extractor until it rests on the spacer.

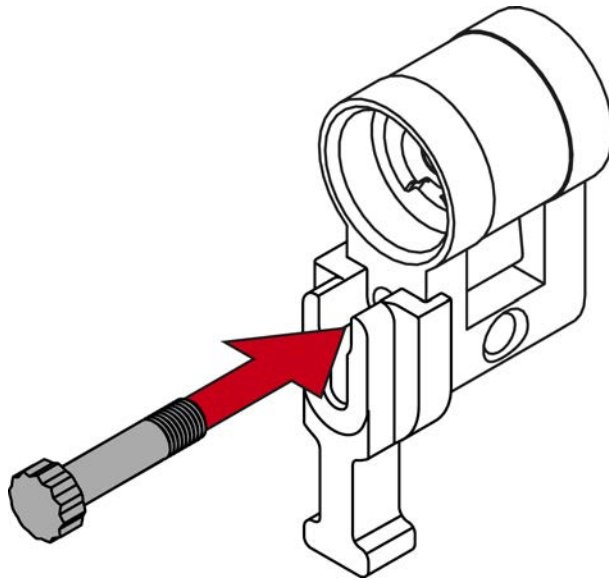

8. Place the prepared cylinder half in the thumb-turn assembly tool.

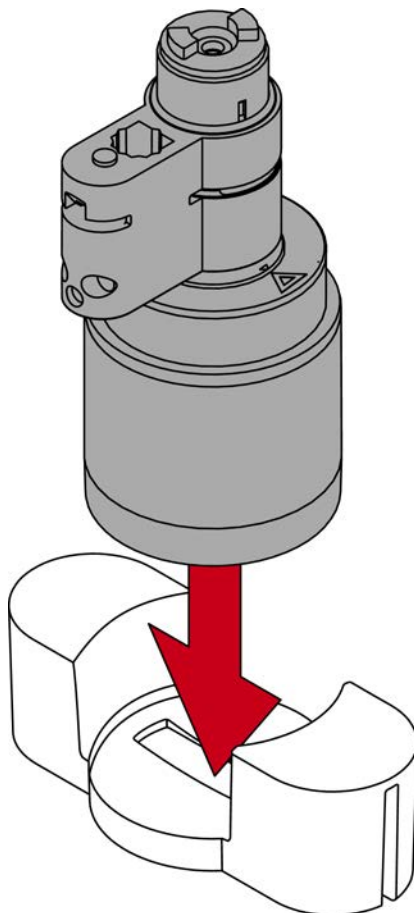

9. Place the half cylinder centre piece on the prepared cylinder half.

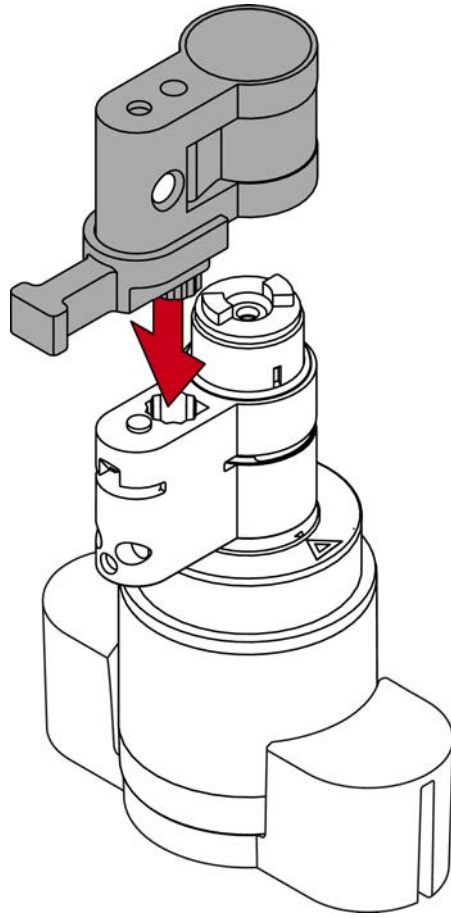

↳ Extension bolt is protected against twisting.

10. Pull the spacer off again.

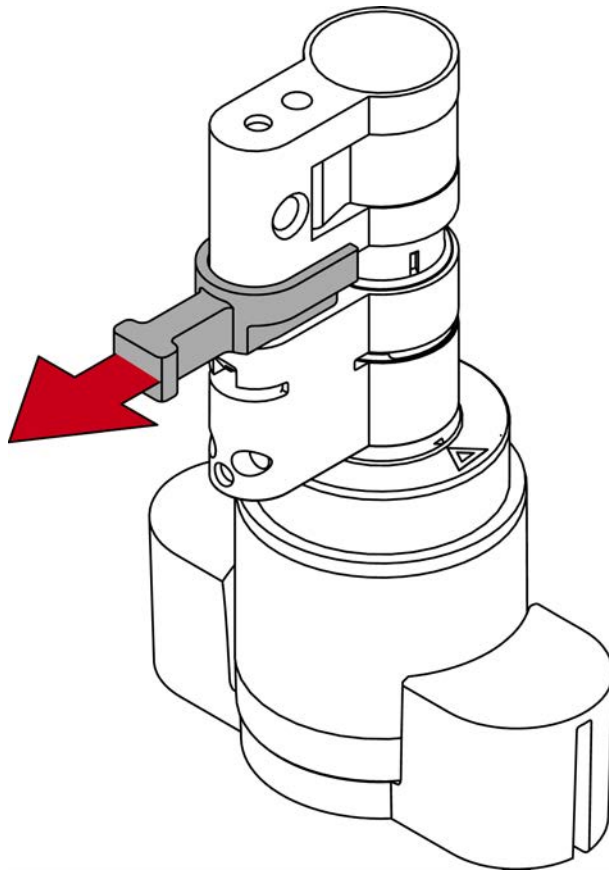



11. Push the cylinder parts together completely.

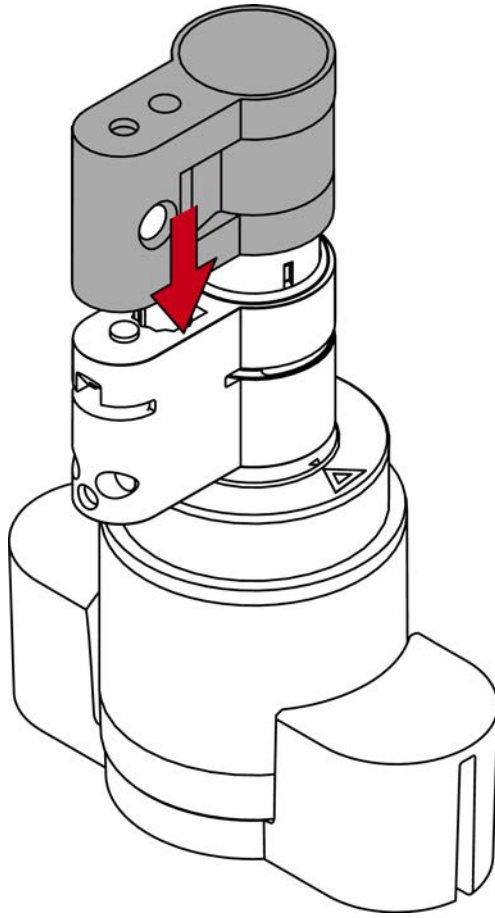

12. Refit the clip into the slot of the profile cylinder with the lug facing the fastening screw.

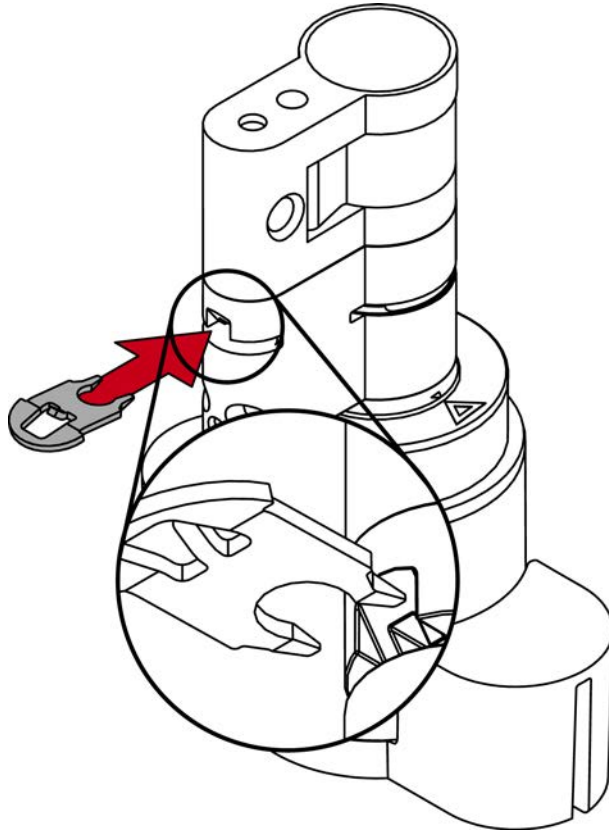

13. Insert the cylinder into the clamping block so that the profile cylinder and the thumb-turn lie flush in the recesses.

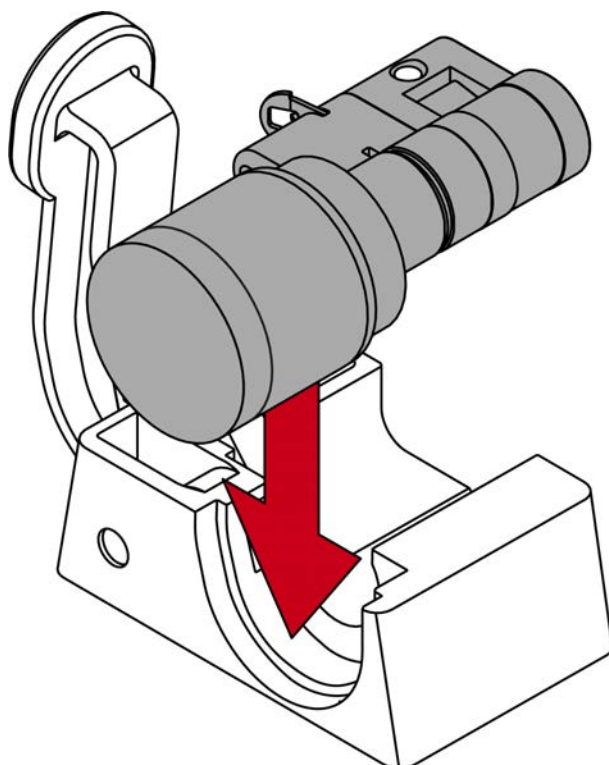

- ↳ The lever of the clamping block is reinforced at one point with a metal plate. The bracket that was previously inserted lies opposite this metal plate.

14. Push the clamp block lever towards the base plate until the clamp is fully seated in the profile cylinder.

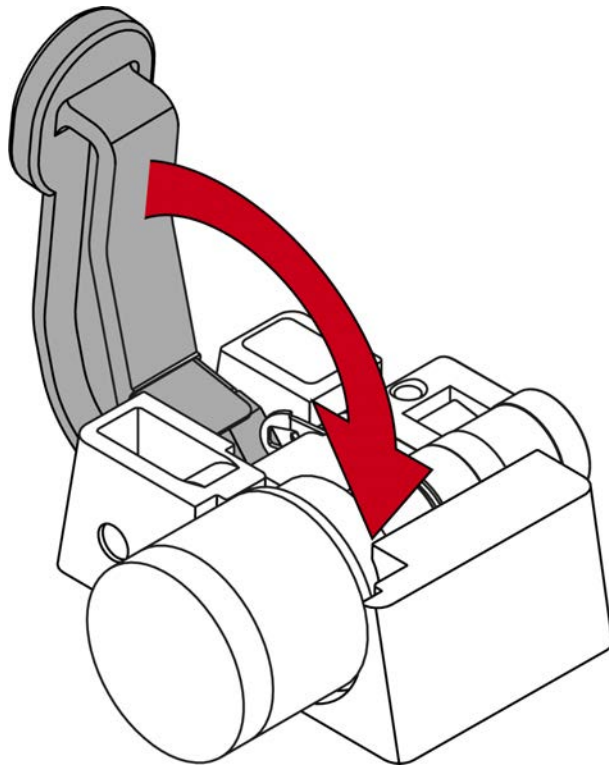

- ↳ Half cylinder AX is fully assembled.

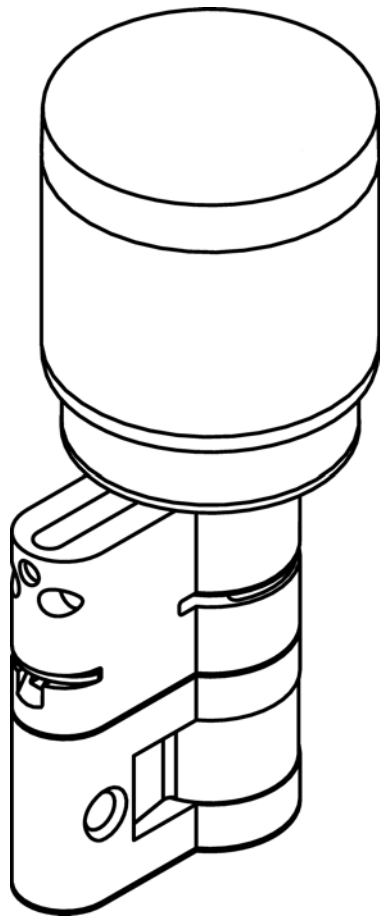

## 8. Replacing the cam

- ✓ Lifter for releasing clamp present.
  - ✓ Spacer for aligning the extension bolt are present.
  - ✓ Suitable tool for pressing the clamp in (e.g. clamping block or fitting pliers) is available.
1. Place the SI Digital Cylinder AX in the thumb turn installation tool.

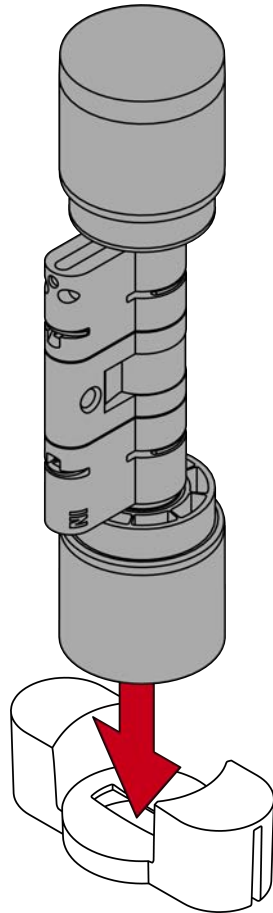

2. Attach the tip of the lifter into the clamp.

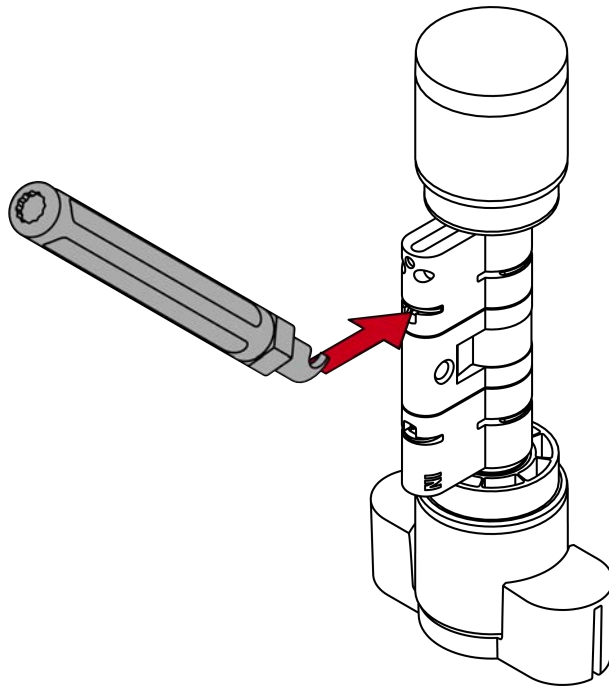

3. Lever the clamp out of the profile cylinder by positioning the lifter in the centre of the cylinder.

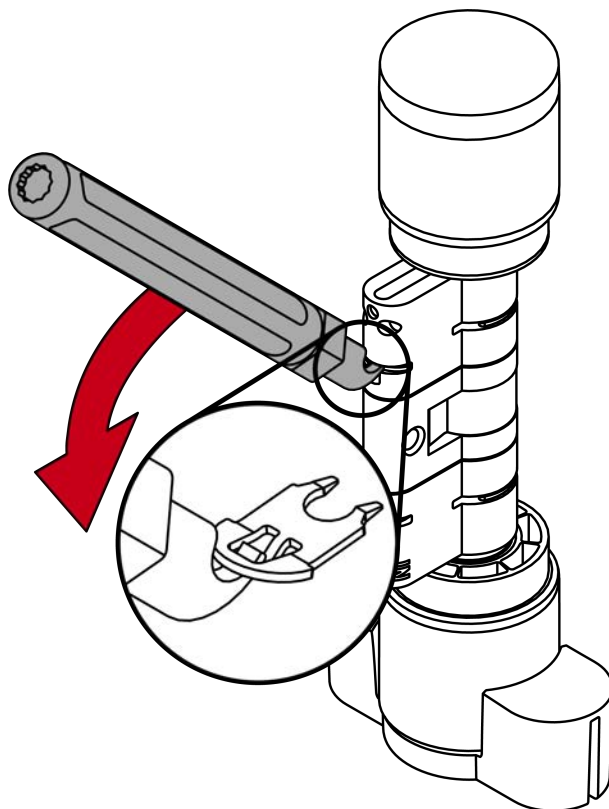

4. Pull the clamp out of the profile cylinder completely.

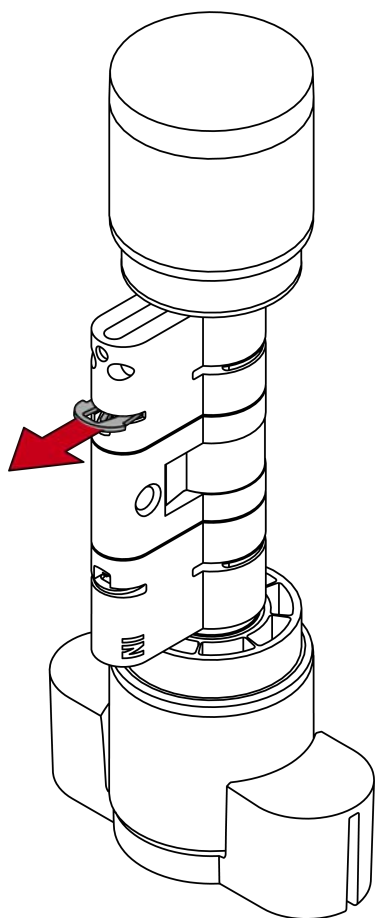

5. Disassemble the two halves of the cylinder.

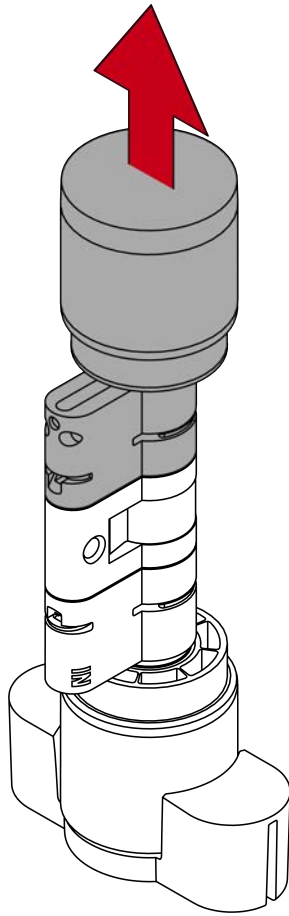

6. Attach the tip of the lifter into the second clamp.

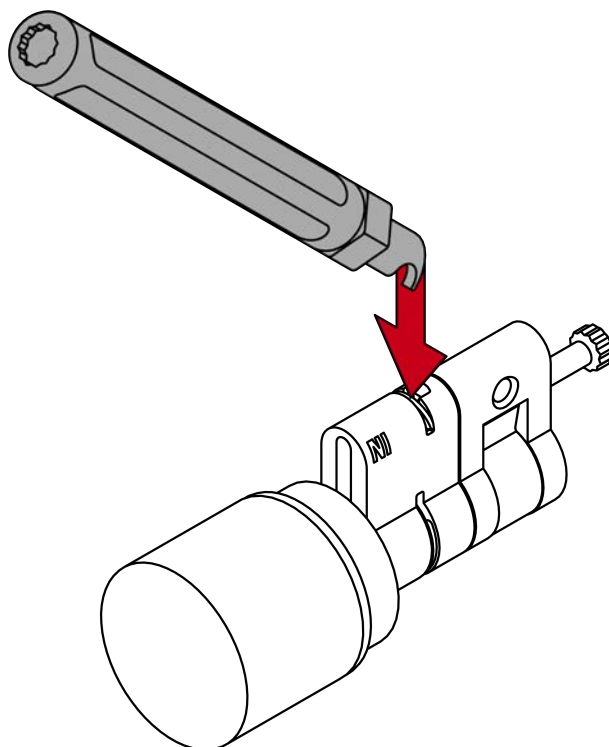



7. Lever the second clamp out of the profile cylinder by positioning the lifter in the centre of the cylinder.

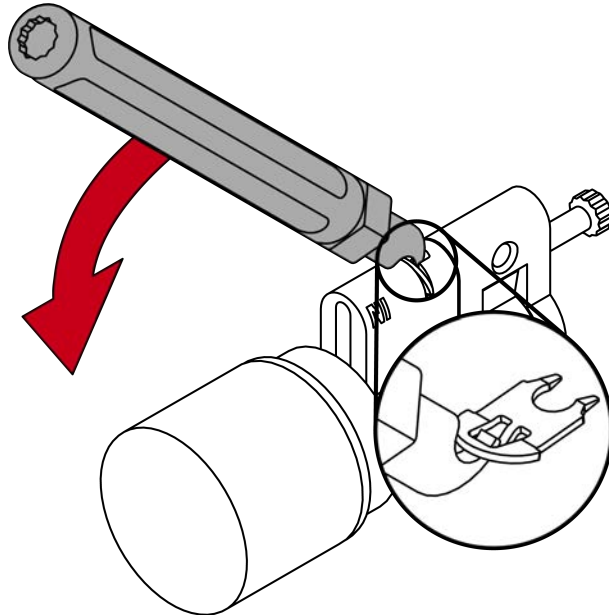

8. Pull the second clamp completely out of the profile cylinder.

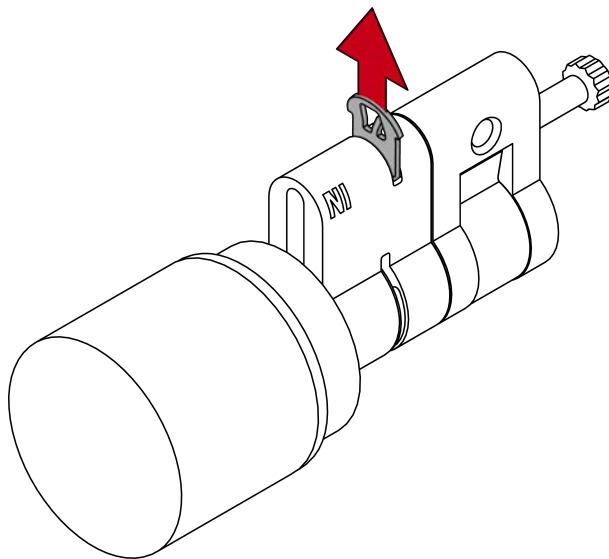

9. Unscrew both extension bolts.

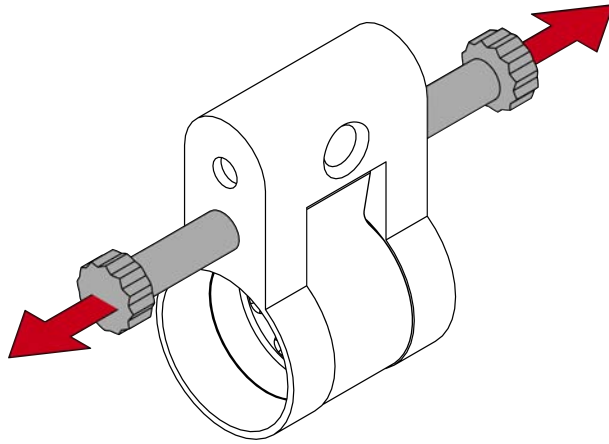

10. Remove the cam.

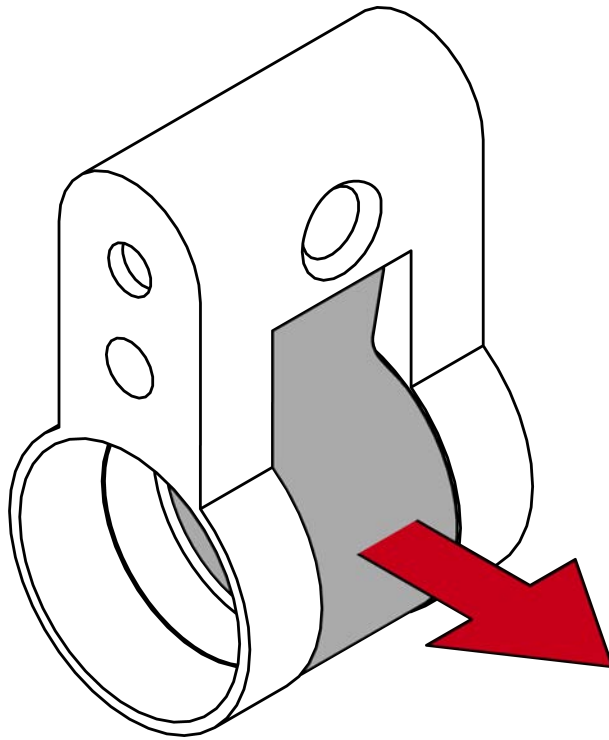

11. Insert a new cam.

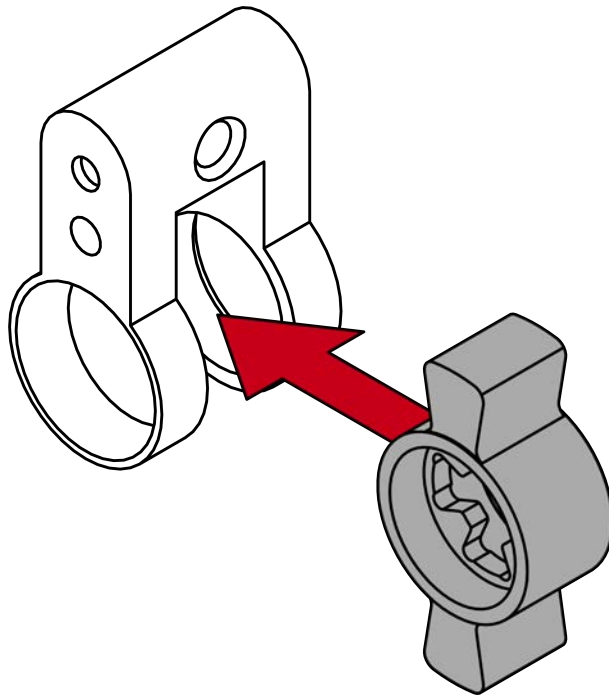

12. Fit the spacer.

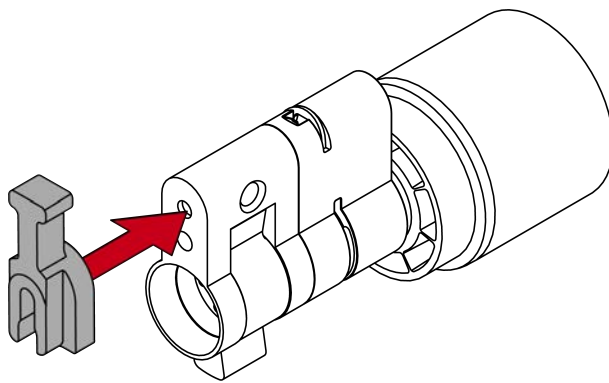

13. Using the lifter, screw in a suitable extension bolt until it is in contact with the spacer.



**NOTE**

**Length on bolt head**

You will find a number on the bolt head. This number is the length of the cylinder profile to which the bolt fits.

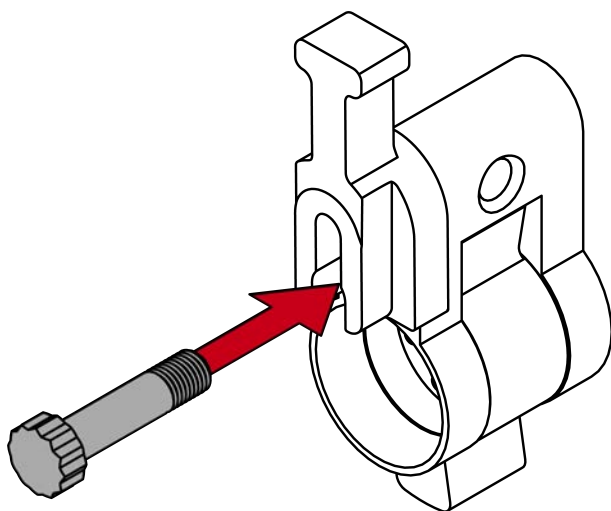

14. Place one half of the cylinder on the extension bolt.

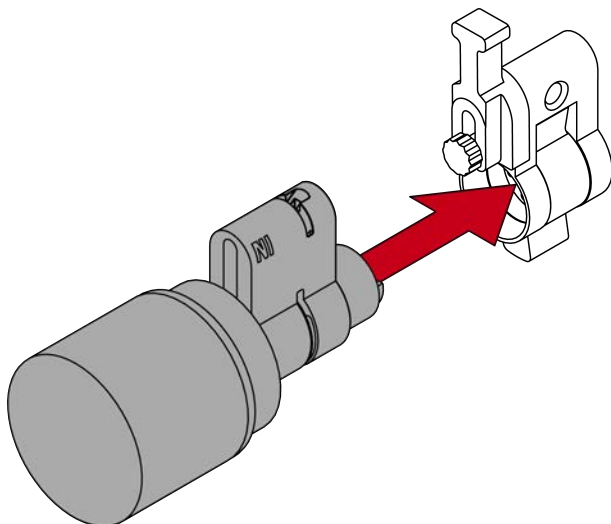

↳ Extension bolt is protected against twisting.

15. Detach the spacer again.

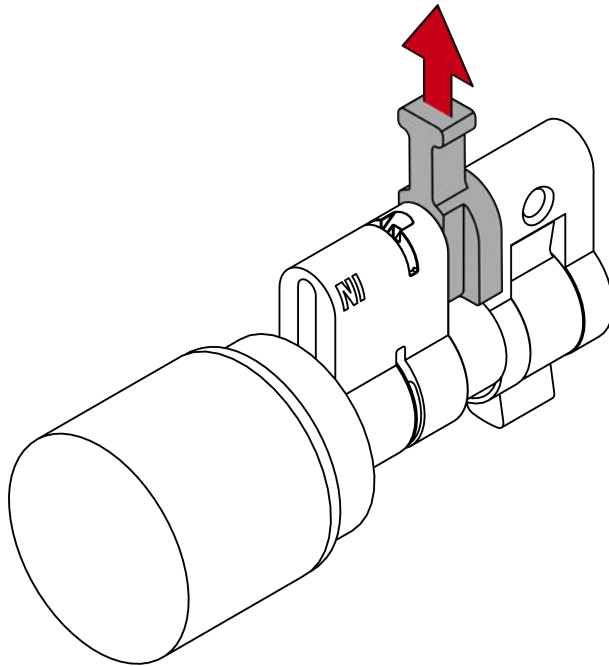

16. Push the halves together completely.

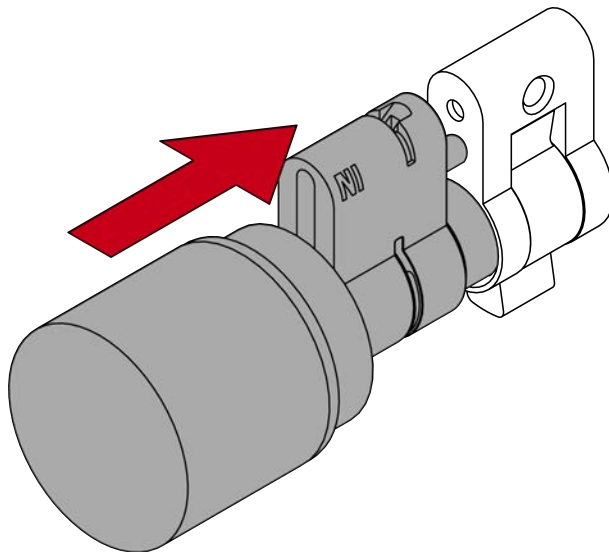

17. Insert the clamp with the tab facing the fastening screw back into the slot in the profile cylinder. Then press the clamp firmly with your thumb so that it can no longer fall out.

18. Press the clamp into the profile cylinder with a suitable tool (e.g. clamping block or fitting pliers).



**NOTE**

**Clamping block incompatible with replacement cams**

Some replacement cams do not fit into the recess in the clamping block. On cylinders with these cams, the clamps cannot be pressed in with the clamping block.

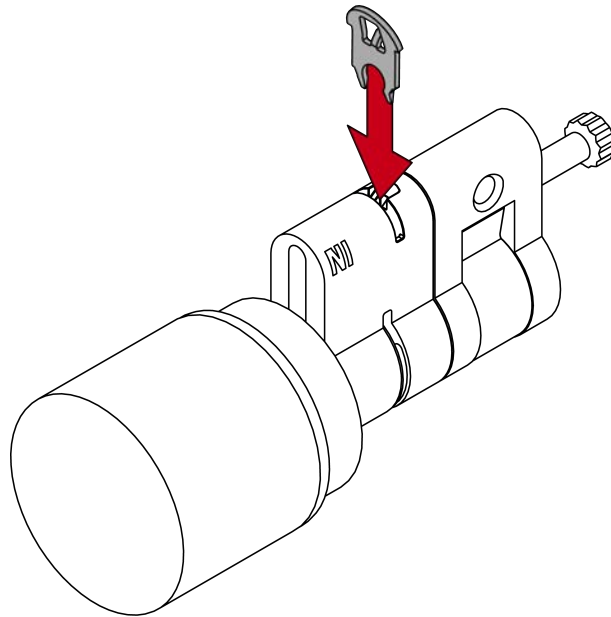

19. Refit the spacer.

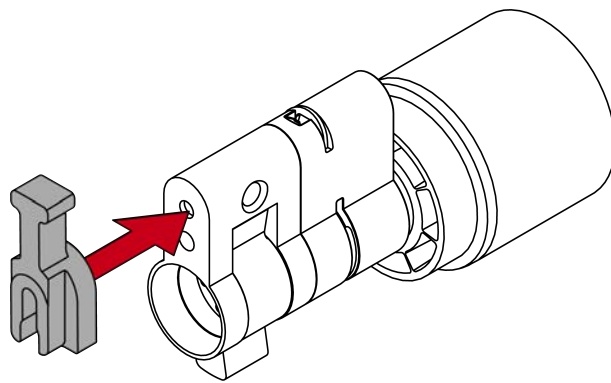

20. Using the lifter, screw in a suitable extension bolt until it is in contact with the spacer.



**NOTE**

**Length on bolt head**

You will find a number on the bolt head. This number is the length of the cylinder profile to which the bolt fits.

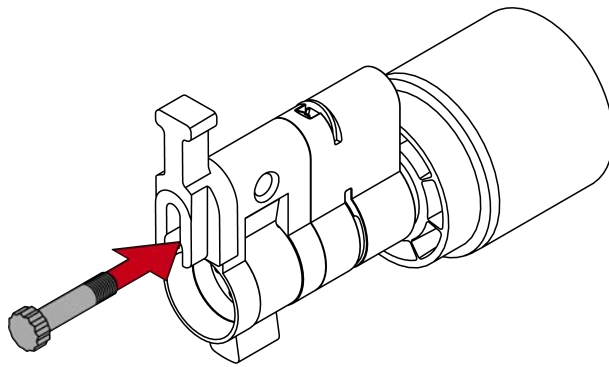

21. Place one half of the cylinder on the extension bolt.  
↳ Extension bolt is protected against twisting.

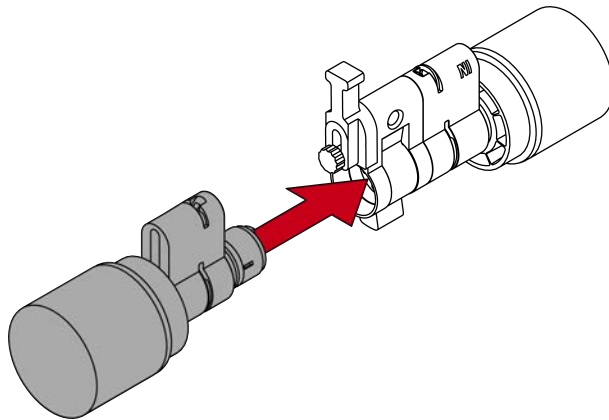

22. Detach the spacer again.

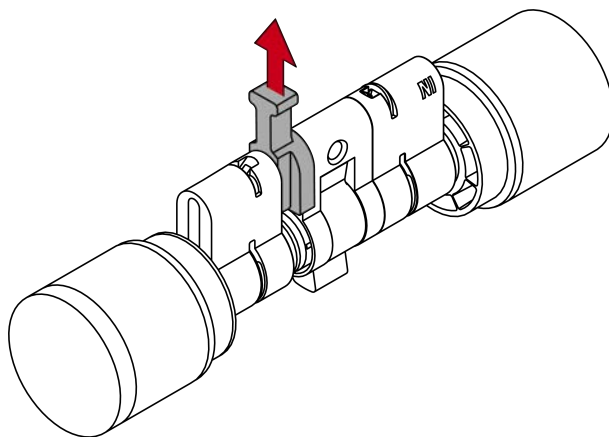

23. Push the halves together completely.

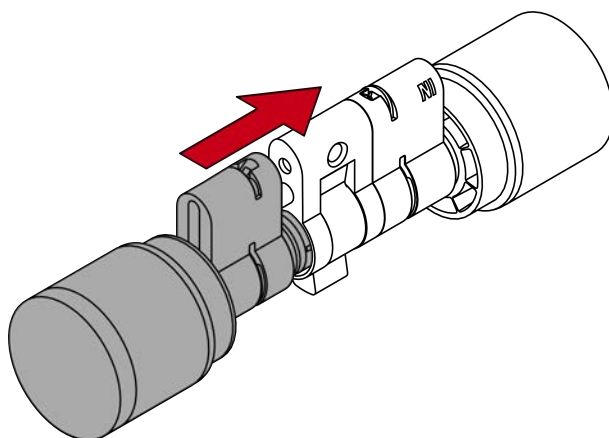

24. Insert the clamp with the tab facing the fastening screw back into the slot in the profile cylinder. Then press the clamp firmly with your thumb so that it can no longer fall out.

25. Press the clamp into the profile cylinder with a suitable tool (e.g. clamping block or fitting pliers).



## NOTE

### Clamping block incompatible with replacement cams

Some replacement cams do not fit into the recess in the clamping block. On cylinders with these cams, the clamps cannot be pressed in with the clamping block.

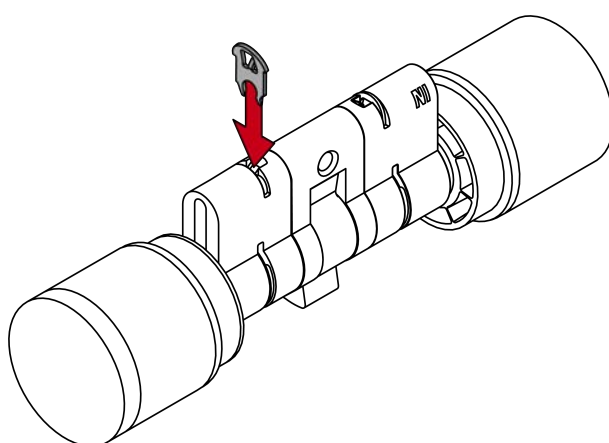

↳ Cam on the SI Digital Cylinder AX has been replaced.



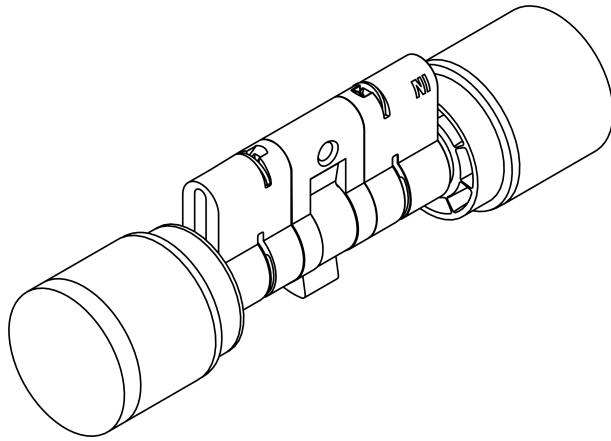

## 9. Help and other information

### Information material/documents

You will find detailed information on operation and configuration and other documents on the website:

<https://www.smartintego.com/int/home/infocenter/documentation>

### Declarations of conformity

You will find declarations of conformity and other certificates on the website:

<https://www.simons-voss.com/en/certificates.html>

### Technical support

Our technical support will be happy to help you (landline, costs depend on provider):

+49 (0) 89 / 99 228 333

### Email

You may prefer to send us an email.

[si-support-simonsvoss@allegion.com](mailto:si-support-simonsvoss@allegion.com)

### FAQs

You will find information and help in the FAQ section:

<https://faq.simons-voss.com/otrs/public.pl>

### Address

SimonsVoss Technologies GmbH  
Feringastr. 4  
D-85774 Unterfoehring  
Germany



## This is SimonsVoss

SimonsVoss, the pioneer in remote-controlled, cable-free locking technology provides system solutions with a wide range of products for SOHOs, SMEs, major companies and public institutions. SimonsVoss locking systems combine intelligent functionality, high quality and award-winning design Made in Germany.

As an innovative system provider, SimonsVoss focuses on scalable systems, high security, reliable components, powerful software and simple operation. As such, SimonsVoss is regarded as a technology leader in digital locking systems.

Our commercial success lies in the courage to innovate, sustainable thinking and action, and heartfelt appreciation of employees and partners.

SimonsVoss is a company in the ALLEGION Group, a globally active network in the security sector. Allegion is represented in around 130 countries worldwide ([www.allegion.com](http://www.allegion.com)).

### Made in Germany

SimonsVoss is truly committed to Germany as a manufacturing location: all products are developed and produced exclusively in Germany.

© 2024, SimonsVoss Technologies GmbH, Unterföhring

All rights are reserved. Text, images and diagrams are protected under copyright law.

The content of this document must not be copied, distributed or modified. More information about this product can be found on the SimonsVoss website. Subject to technical changes.

SimonsVoss and MobileKey are registered brands belonging to SimonsVoss Technologies GmbH.

**SimonsVoss**  
technologies

Made in Germany

A BRAND OF

  
**ALLEGION**